



INSTALLATION INSTRUCTIONS

Accessory

CASSETTE PLAYER
P/N 08A03-5C2-050

Application

Publications No.

BII 26193

Issue Date

SEP 2003

PARTS LIST

Cassette player

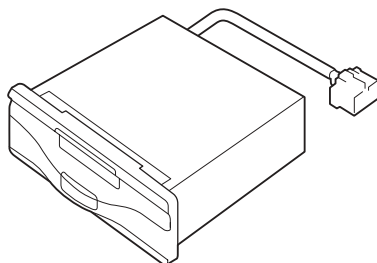

Owner's Manual

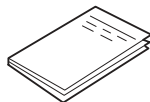

5 Washer-screws, 5 x 8 mm



Wire tie

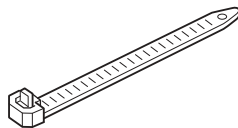

Harness clip

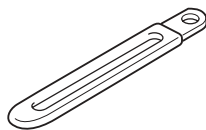

TOOLS AND SUPPLIES REQUIRED

- Phillips screwdriver
- Stubby Phillips screwdriver
- Ratchet
- 8 mm and 10 mm Sockets
- Shop towel
- Diagonal cutters

INSTALLATION

Customer Information: The information in this installation instruction is intended for use only by skilled technicians who have the proper tools, equipment, and training to correctly and safely add equipment to your vehicle. These procedures should not be attempted by "do-it-yourselfers."

1. If equipped, make sure you have the anti-theft code for the radio, then write down the radio station presets.
2. Disconnect the negative cable from the battery.
3. Pry up on the seven clips, and remove the center lower cover. Unplug the accessory socket connector. Take care not to damage the clips.

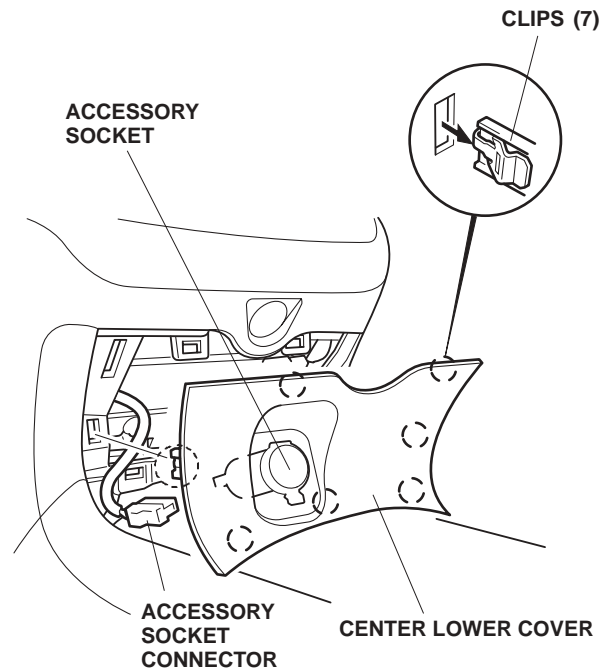

- Using a stubby Phillips screwdriver, remove the two bolts that fasten the center panel.

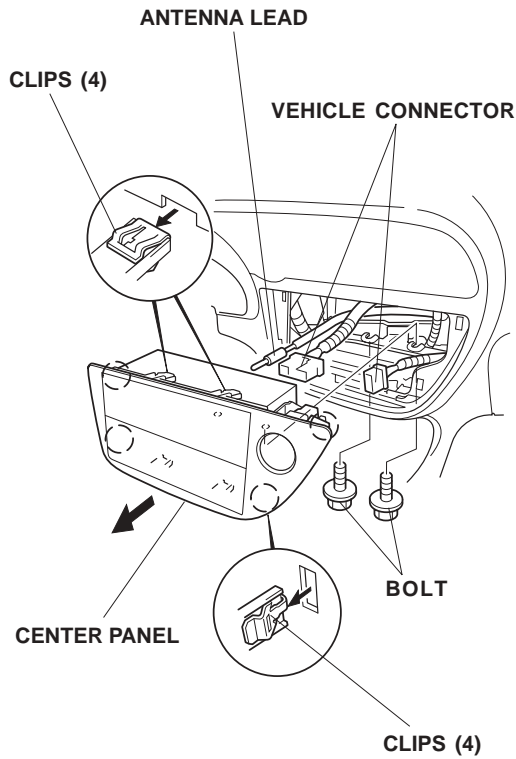

- Pull the center panel toward you to release the eight clips, unplug the connectors and the antenna lead, and remove the center panel. Take care not to damage the clips.
- Remove the hazard switch from the center panel (two self-tapping screws).

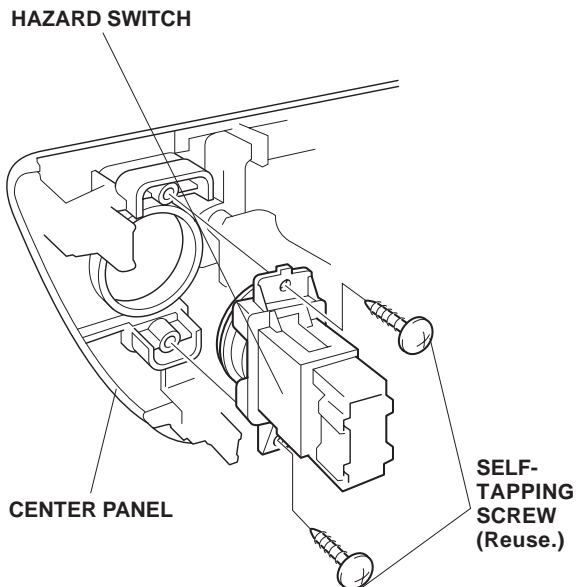

- Remove the radio from the center panel bracket (four bolts).

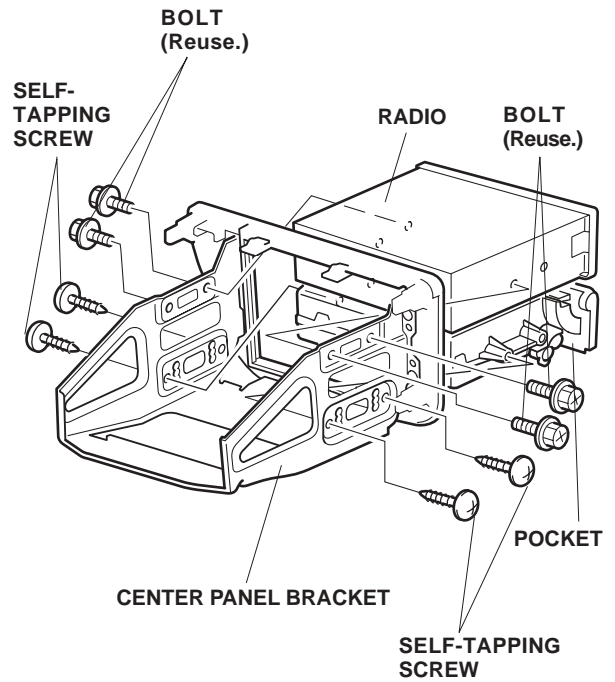

- Remove the pocket from the center panel bracket (four self-tapping screws). Save the pocket and the self-tapping screws for your customer in case the cassette player needs to be removed.

- Stack the radio on top of the cassette player, and slide them into the center panel bracket. Install the radio with the four bolts removed in step 7, and install the cassette player with four 5 x 8 mm washer-screws supplied.

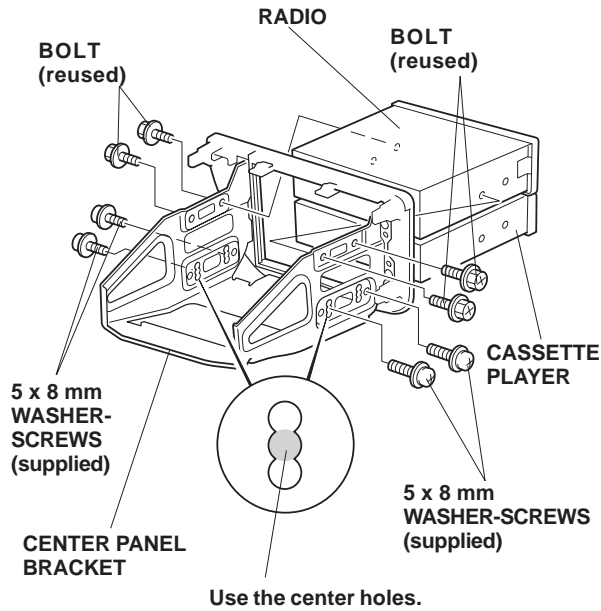

- Slightly bend the harness clip, and attach it to the rear of the cassette player with one 5 x 8 mm washer-screw supplied.

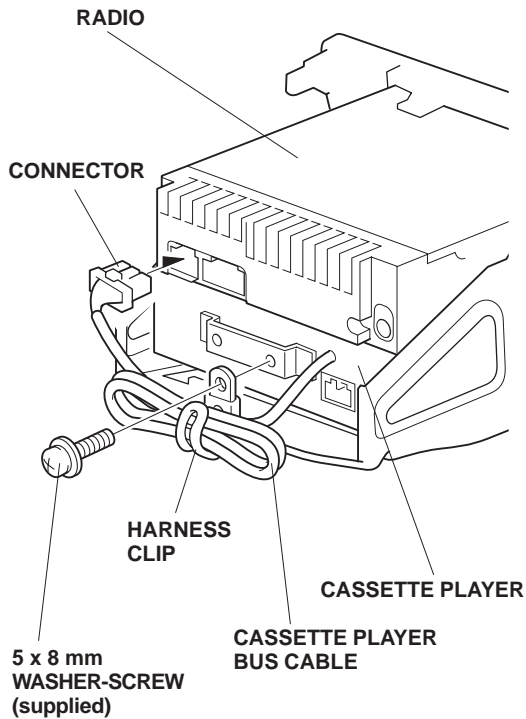

- Loop the BUS cable, and attach it to the harness clip. Plug the connector of the BUS cable into the rear of the radio.

- Reinstall the hazard switch using the two self-tapping screws you removed in step 6.

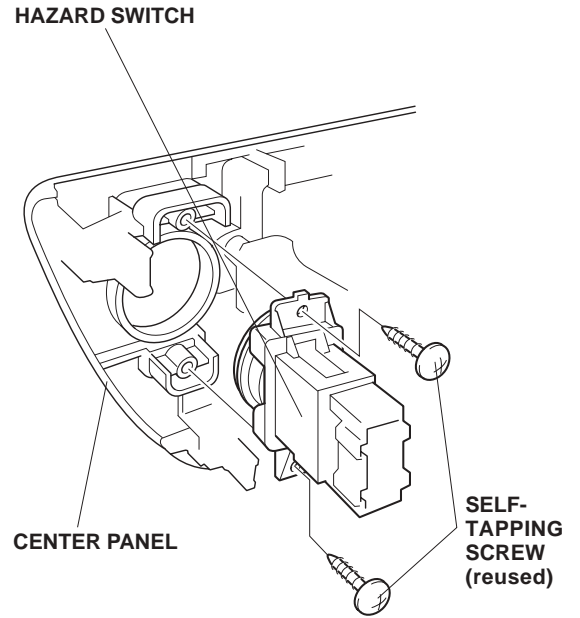

13. Plug the antenna lead and the vehicle harness connectors into the rear of the radio and the hazard switch. Slide the center panel into the radio opening, and secure it with two bolts. Using a 10 mm wrench, tighten the bolts securely.

- **Without CD Changer:**

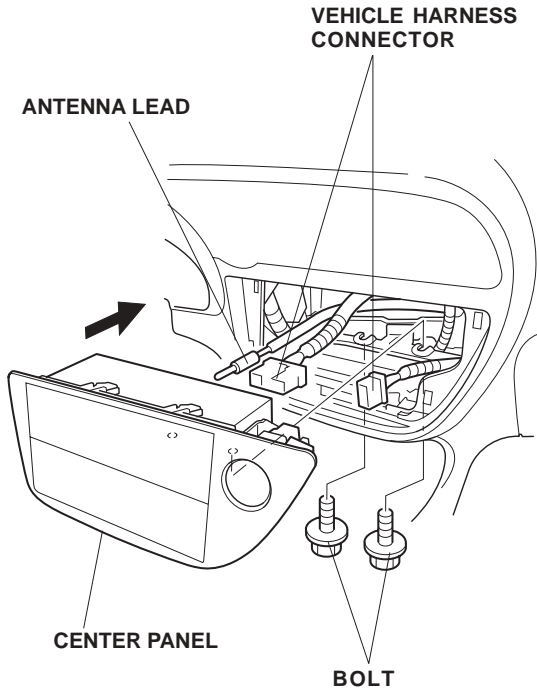

- **With CD Changer:** Plug the connector of the CD changer BUS cable into the cassette player.

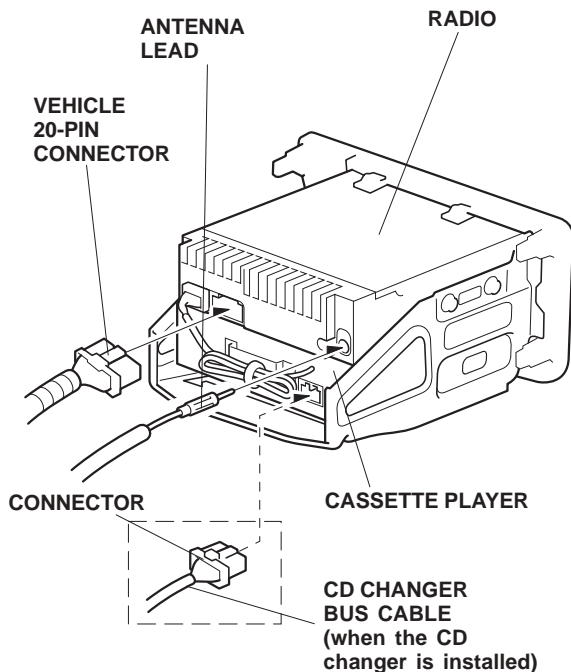

14. Reconnect the negative cable to the battery.
15. Check the operation of the cassette player according to the Owner's Manual supplied.
16. Enter the radio anti-theft code, and reset the customer's radio station presets.
17. Reset the clock.
18. Put the cassette player Owner's Manual and the pocket and screws (removed in step 8) into the glove box.

NOTE: Whenever the battery is disconnected, the driver's window AUTO function is disabled.

19. Start the engine. Push down on the driver's window switch until the window is fully open.
20. Pull up on the driver's window switch to close the window completely, then hold the switch for a second or two more.
21. Test the window AUTO function.
22. Do the ECM/PCM idle learn procedure.

- Make sure all electrical items are turned off.
- Start the engine. Hold the engine speed at 3,000 rpm with no load (in Park or Neutral) until the radiator fan comes on.
- Let the engine idle for about 5 minutes with the throttle fully closed and with all electrical items off.

NOTE: If the radiator fan comes on during this step, the time when it is operating must not be included in the 5 minutes.