



# INSTALLATION INSTRUCTIONS

Accessory

Application

Publications No.

**BII 32608**

Issue Date

**JUL 2006**

**MOONROOF VISOR**  
P/N 08R01-STK-200

**Put this information in the glove box with the vehicle owner's manual.**

## PARTS LIST

Moonroof visor

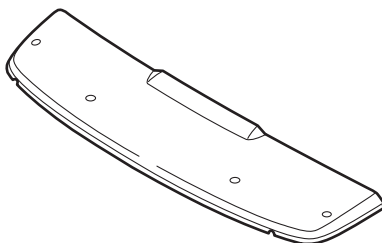

2 Front brackets

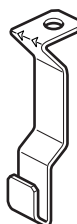

2 Side brackets

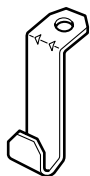

4 Screws



4 Nuts



4 Protective tapes



## TOOLS AND SUPPLIES REQUIRED

Phillips screwdriver

10 mm Combination wrench

Scale

Isopropyl alcohol

Shop towel

Masking tape

Felt-tip pen

Torque wrench

## INSTALLATION

1. Clean and wax the roof area to be covered with a high-quality paste wax.
2. Open the moonroof.
3. Roll up two shop towels, and insert them between the roof panel and air deflector to lower the air deflector. Take care not to damage the air deflector.

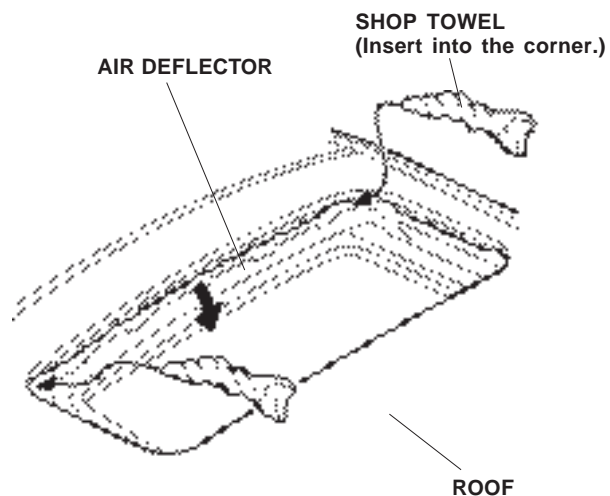

- At the left front corner of the moonroof opening, locate the front moonroof guide rail screw. From the guide rail screw, place a scale directly outboard from the screw as shown, and mark the edge of the roof with a felt-tip pen.

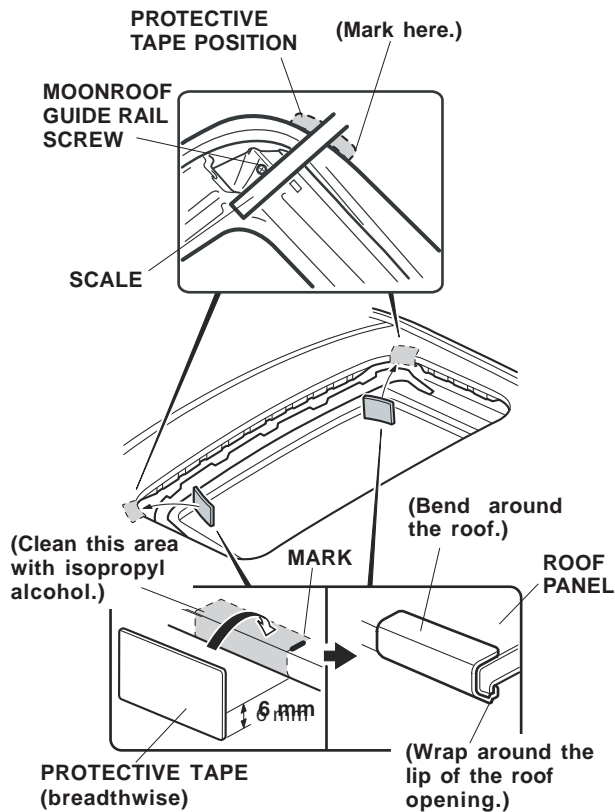

- Using isopropyl alcohol on a shop towel, clean the roof area and the inside edge of the moonroof opening at the mark.
- Remove the adhesive backing from one protective tape. Starting at the bottom edge, wrap the protective tape around the lip of the moonroof opening at the center of the mark; continue upward with the tape around the top of the roof panel.
- Repeat steps 4 thru 6 to install the protective tape on the right side of the moonroof opening. Remove the marks you made using isopropyl alcohol on a shop towel.

- At the front of the moonroof opening, locate the third weld mark from the end.

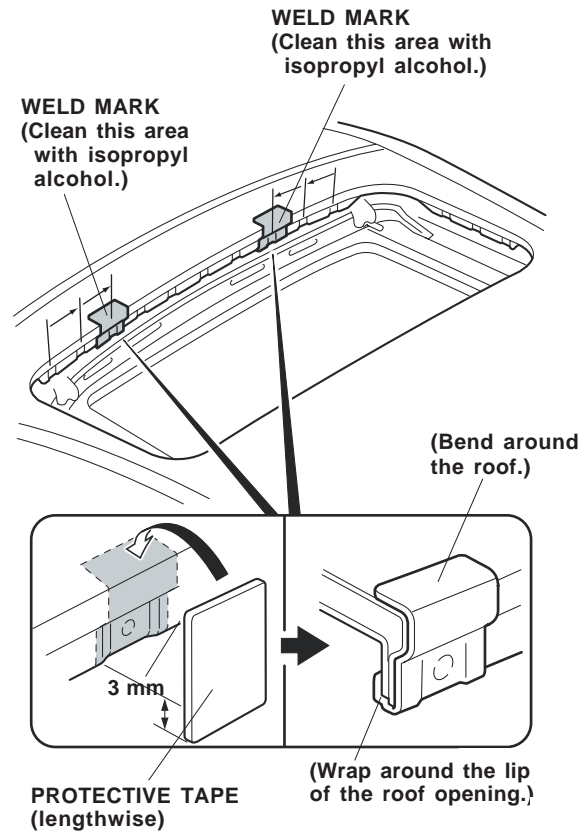

- Using isopropyl alcohol on a shop towel clean the third weld mark where the protective tape will be applied.
- Remove the adhesive backing from one of the protective tapes. Starting at the bottom edge of the tape, wrap the protective tape around the lip of the moonroof opening to cover one of the located weld marks. Continue upward, bending the tape around the top of the roof panel.
- Using the same procedure, attach the other protective tape to the roof at the other located weld mark.

12. Place the two front brackets and two side brackets into position over the protective tape and around the lip of the roof edge, and tape them into position with a piece of masking tape.

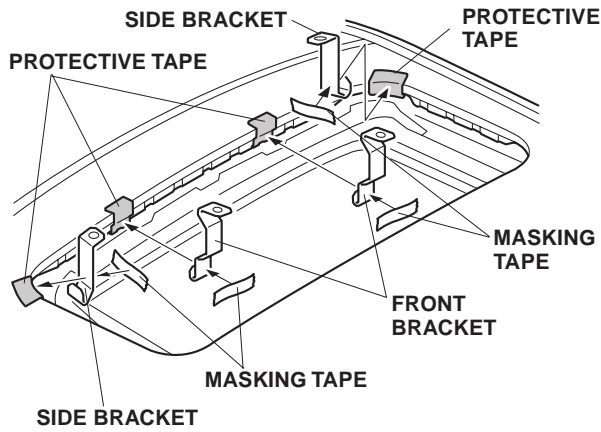

13. Set the moonroof visor on the vehicle roof in front of the moonroof opening, and adjust its position so the holes in the visor are aligned with the side bracket holes. Install two screws and two nuts loosely onto the side brackets.

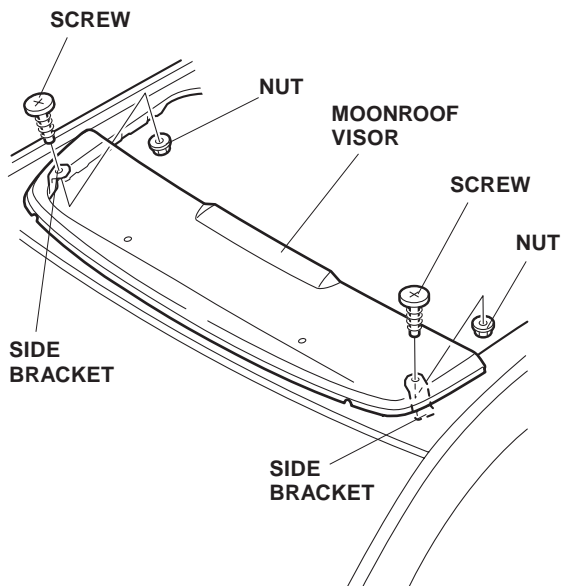

14. Align the front bracket holes with the moonroof visor holes. Install the two screws and two nuts loosely onto the front brackets.

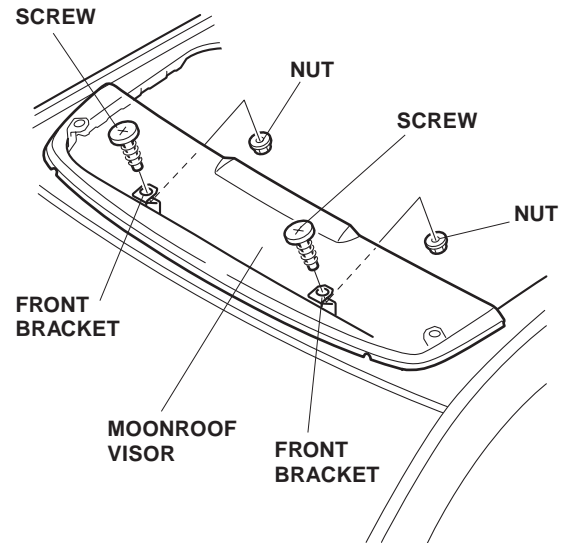

- Position the moonroof visor with equal spacing on all sides. Check that the rubber seal is not twisted or rolled under the visor.

**FRONT BRACKET**

(Make sure the bracket is tight against the lip of the moonroof opening.)

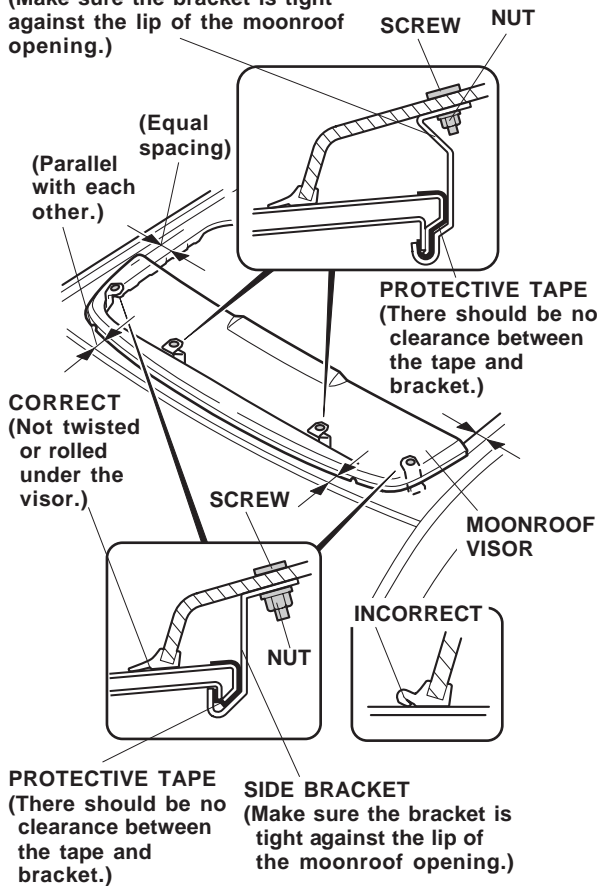

- Tighten the nuts and screws, alternating between side and front bracket. To prevent damage to the moonroof visor and the resin nuts, do not overtighten the screws. Torque: 2 N·m (1.5 lb-ft)

**CARE OF THE MOONROOF VISOR**

- To avoid damaging the surface, never use ammonia-based cleaners or solvents to clean the moonroof visor.
- Clean with a solution of mild dishwashing soap and water using a soft cloth or chamois.
- To remove fine scratches and restore the original luster, use Meguiar's Mirror Glaze plastic cleaner and polish or an equivalent high-quality plastic cleaner.