

ACURA
INSTALLATION
INSTRUCTIONS

Accessory

Application

Publications No.

BII 32602**REAR DIFFUSER**

Issue Date

AUG 2006**PARTS LIST**

Rear diffuser

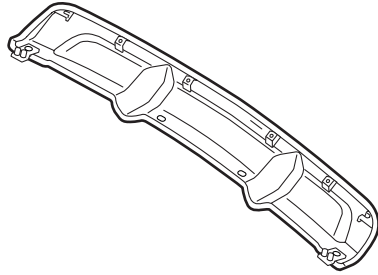

2 Screws, 6 x 12 mm



6 Self-tapping screws, 5 x 12 mm



6 Spring nuts



2 Washers, 6 mm



6 Washers, 5 mm



2 Bumper bolts



2 Flange nuts

**TOOLS AND SUPPLIES REQUIRED**

Phillips screwdriver

Flat-tip screwdriver

File

Drill

3 mm, 6 mm, 8 mm, 10 mm, and 11 mm Drillbits

Clip remover

Pushpin

Eye protection (face shield, safety goggles, etc.)

Blanket

Saw blade

INSTALLATION

Customer Information: The information in this installation instruction is intended for use only by skilled technicians who have the proper tools, equipment, and training to correctly and safely add equipment to your vehicle. These procedures should not be attempted by "do-it-yourselfers."

NOTE: Be careful not to damage the rear bumper and body paint finish.

If the vehicle is equipped with a trailer hitch, continue with step 1, otherwise, go to step 4.

1. Inside the rear diffuser, locate the scribe marks, and using a pushpin, pierce through the rear diffuser at each scribe mark.

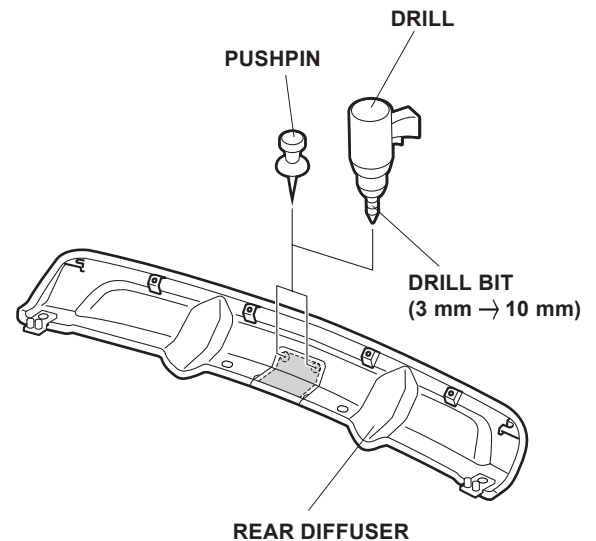

2. While wearing eye protection, drill a 10 mm hole at each pierced mark. First drill with a 3 mm drill bit, and finish with a 10 mm drill bit.

- Using a saw blade, cut out the rear diffuser along the holes you drilled in step 2.

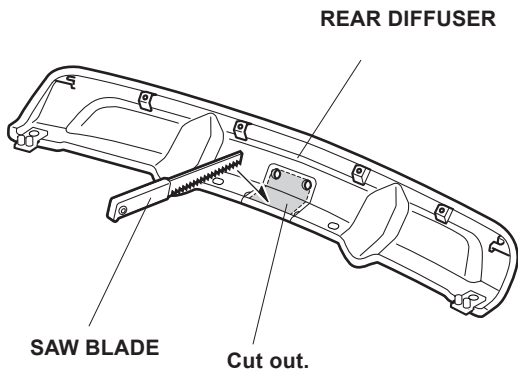

- Remove the rear bumper.

- Remove the rear bumper weatherstrip in the area shown.
- Remove the four caps and four bolts from the rear bumper.
- Remove the four self-tapping screws and four clips.
- With the help of an assistant, remove the rear bumper.
- To prevent scratching the bumper, set it on a blanket.

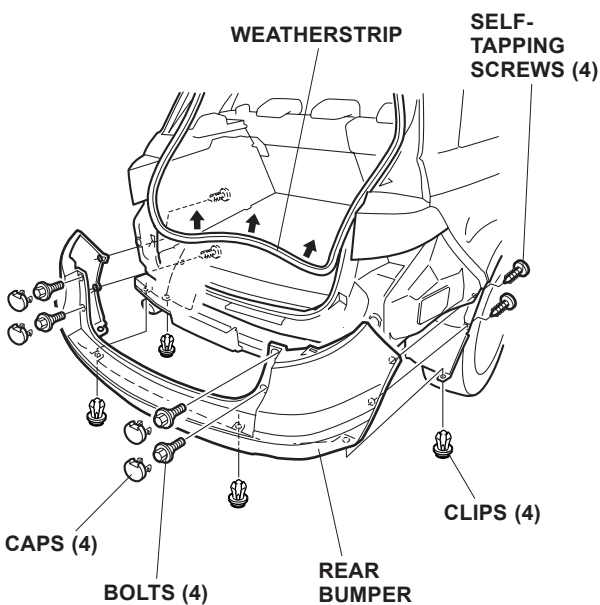

- Inside the bumper, locate the four scribe marks in the area shown. Using a pushpin, pierce the cross sections of each scribe mark.

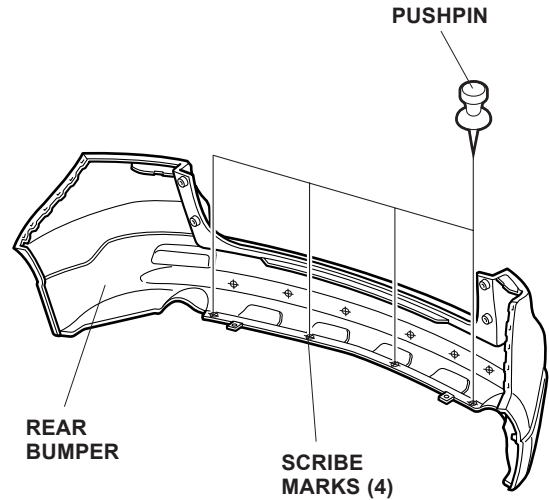

- Inside the bumper, locate the six scribe marks in the area shown. Using a pushpin, pierce the cross sections of each scribe mark.

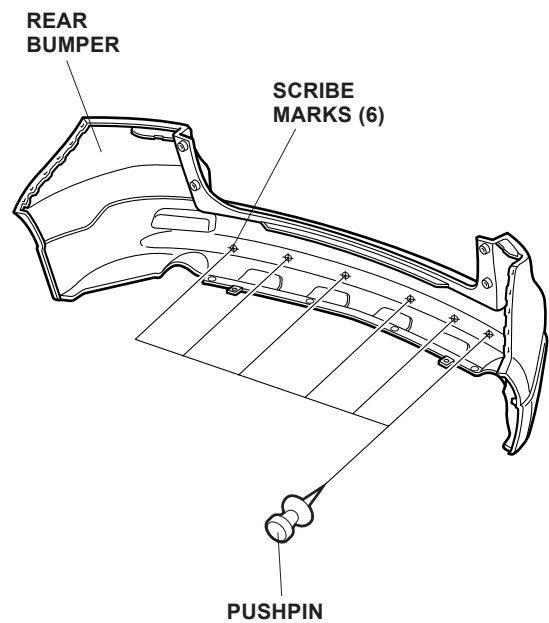

7. While wearing eye protection, drill a 3 mm hole through each marked location on the bumper. Enlarge the inner holes to 11 mm using an 11 mm drill bit. Enlarge the outer holes to 8 mm using an 8 mm drill bit. Remove any burrs from the edges of the holes with a file.

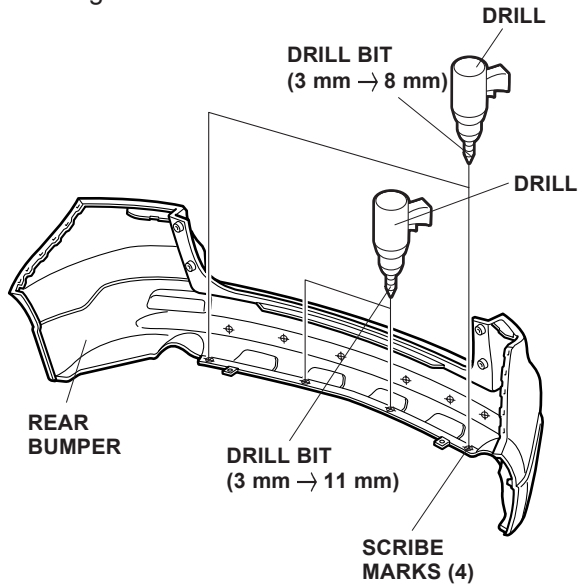

8. While wearing eye protection, drill a 3 mm hole through each marked location from the inside of the bumper, and finish with a 6 mm drill bit. Remove any burrs from the edges of the holes with a file.

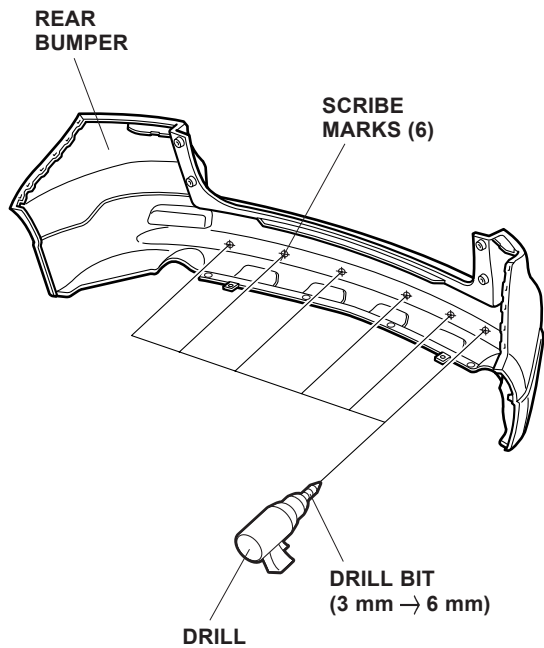

9. Slide the six spring nuts onto the rear diffuser.

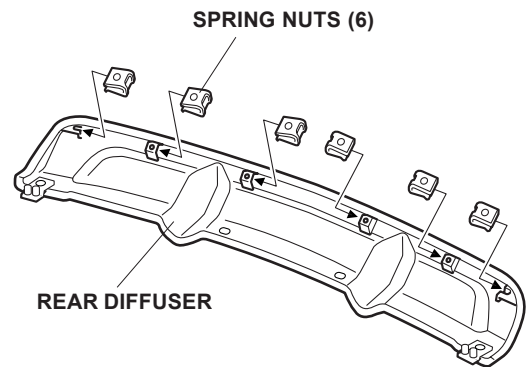

10. Install the rear diffuser on the rear bumper using two 6 x 12 mm screws, two 6 mm washers, two bumper bolts, and two flange nuts.

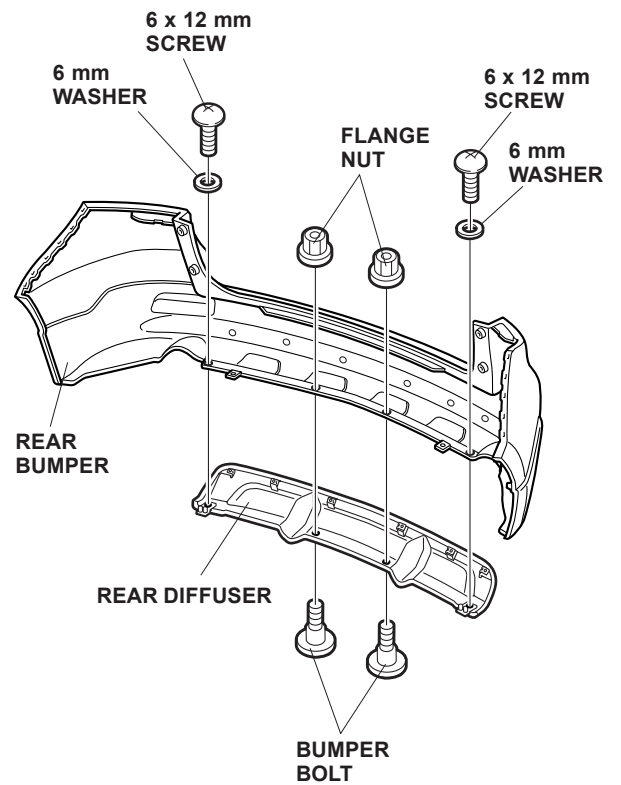

11. Secure the rear diffuser to the rear bumper using six 5 x 12 mm self-tapping screws and six 5 mm washers.

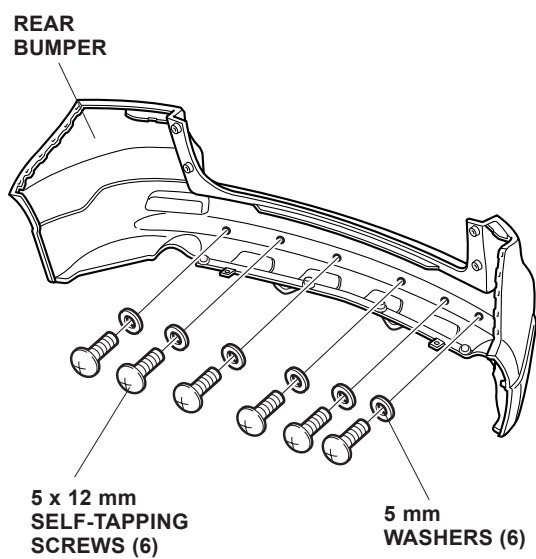

12. Reinstall the rear bumper.