



# INSTALLATION INSTRUCTIONS

Accessory	Application	Publications No.
<b>REAR SPEAKER KIT P/N 08A54-S3Y-100</b>	<b>INSIGHT</b>	<b>All 23272</b>
		Issue Date
		<b>OCT 2001</b>

## PARTS LIST

Template

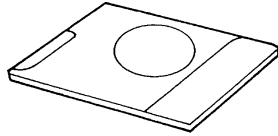

2 Speaker brackets

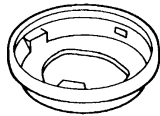

2 Speaker covers

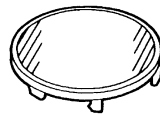

6 Self-tapping screws



6 Screw grommets



EPT sealer

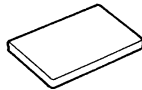

2 Speakers

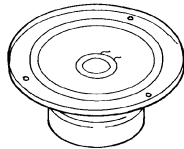

## TOOLS AND SUPPLIES REQUIRED

Phillips screwdriver

Utility knife

Scissors

Felt-tip pen

## INSTALLATION

### NOTE:

- These instructions show the right speaker being installed. The same procedure applies to installing the left speaker.
- Be careful not to damage the linings.

1. Using scissors, cut out the template as indicated.
2. Slide the passenger's seat all the way forward, and tilt the seat-back forward. Position the template on the bulkhead carpet in the area shown, then mark the edge of the hole in the template on the carpet with a felt-tip pen. Remove the template.

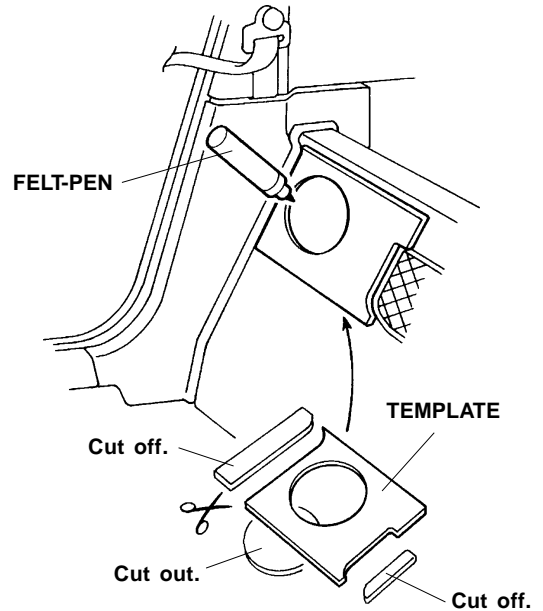

3. Cut out the marked area from the carpet with a utility knife and scissors as described.

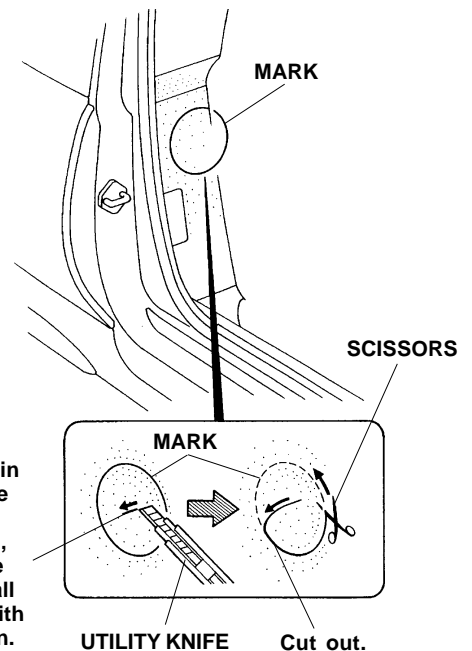

- Remove the speaker hole cover, and disconnect the 2-pin connector secured to the back of the cover. Pull the 2-pin connector out of the speaker hole as shown. Discard the cover.
- Cut an EPT sealer into halves, then wrap one half of the EPT sealer around the right harness at a point about 10 mm away from the connector as indicated.

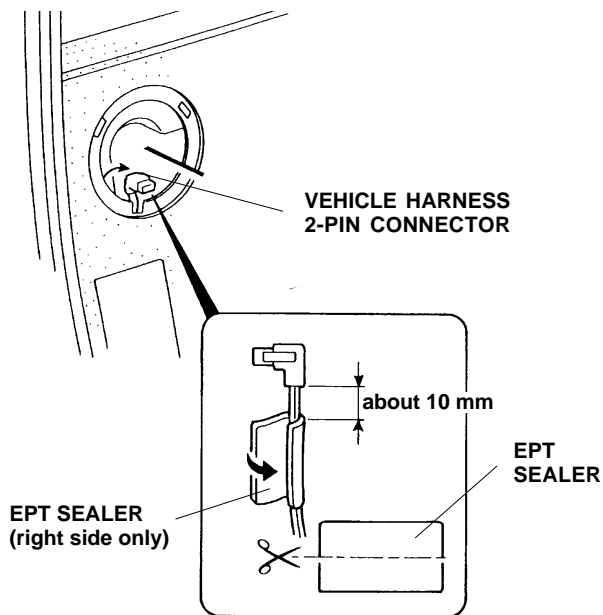

- Inside the right speaker hole, attach the other half of the EPT sealer to the bracket for the duct as shown.
- Push a screw grommet from the kit into each of the three square holes in the edge of the speaker opening.

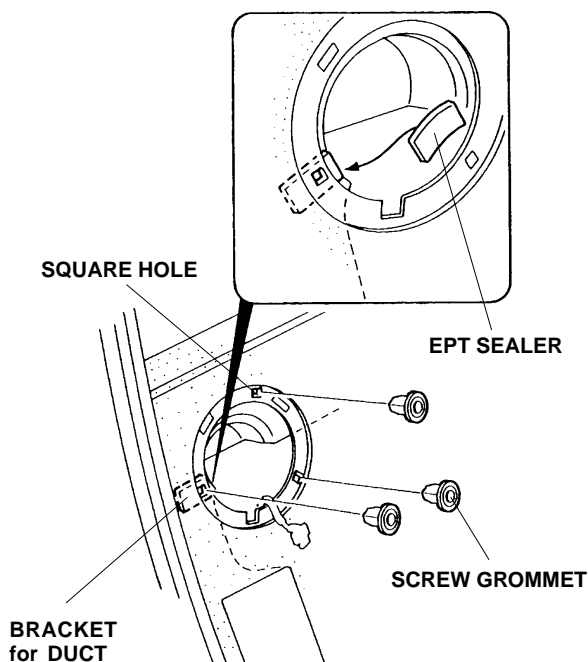

- Position the speaker trim over the speaker opening, and align their holes. Plug the 2-pin connector of the vehicle's speaker harness onto the terminals on the speaker, then position the speaker on the speaker trim. Install and tighten the three self-tapping screws securely.

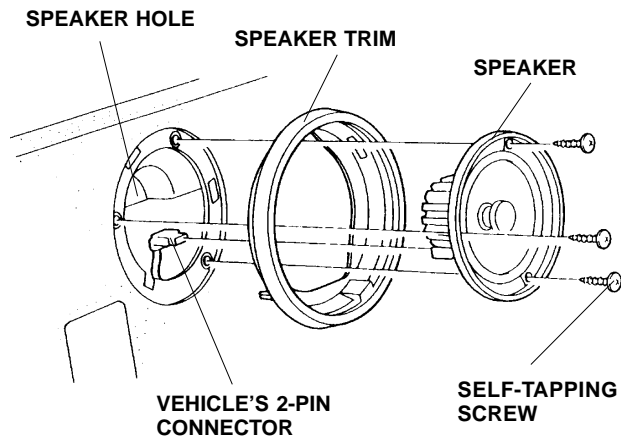

- Install the speaker cover.

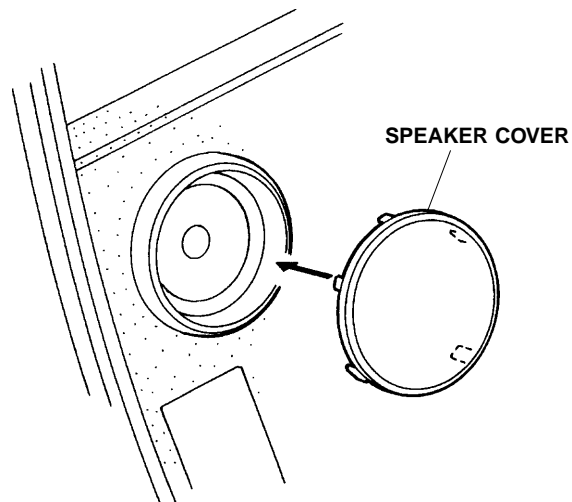

- Repeat steps 2 through 4, and 7 through 9 to install the speaker on the driver's side.
- Check that all wire harnesses are routed properly and all connectors are plugged in.
- Turn on the radio, and check the rear speakers for proper operation.