

## INSTALLATION

**Customer Information:** The information in this installation instruction is intended for use only by skilled technicians who have the proper tools, equipment, and training to correctly and safely add equipment to your vehicle. These procedures should not be attempted by "do-it-yourselfers."

1. Make sure you have the anti-theft code for the radio, then write down the frequencies for the preset buttons.
2. Disconnect the negative cable from the battery.
3. Wrap the shop towel to the top of the flat-tip screwdriver, and insert it to grooves in the audio panel. Pull the audio panel out toward you to release the five clips and remove the audio panel. Take care not to damage the clips.

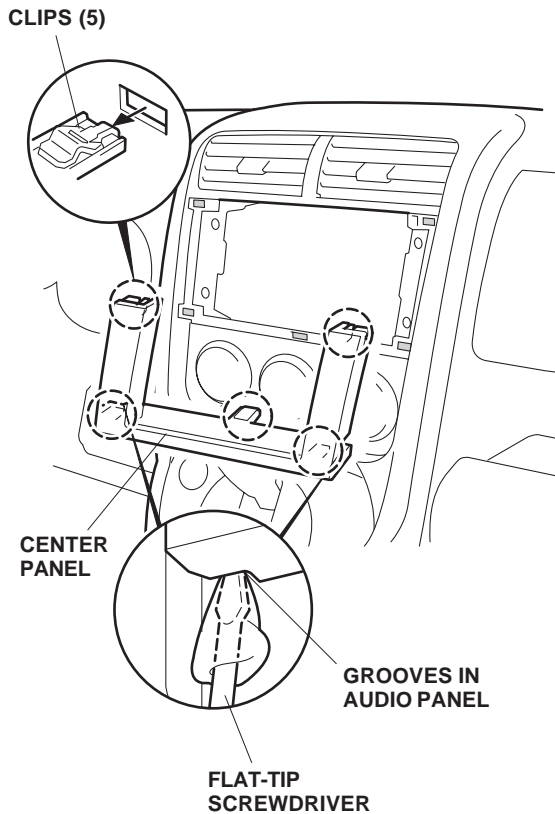

4. Remove the four self-tapping screws and pull out the audio unit.
5. Disconnect the vehicle connector (three connectors on EX model) and the antenna lead, then remove the audio unit.

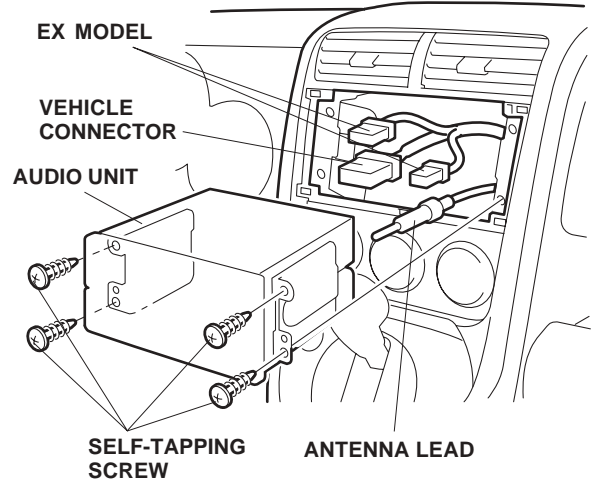

## Connecting the BUS Cable and Audio Unit

6. Plug the BUS cable 14-pin connector, the vehicle 20-pin connector, and antenna lead into the back of the AM/FM CD Tuner.

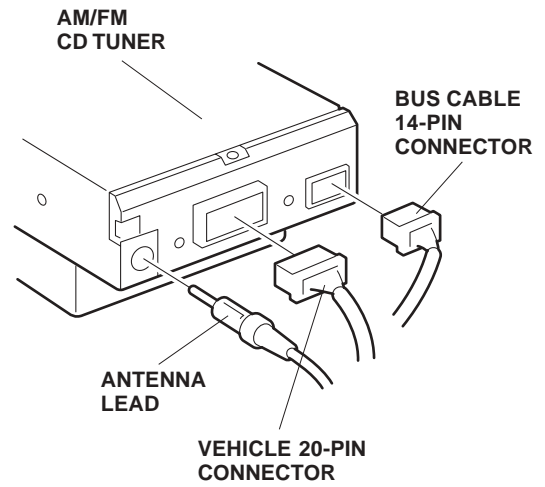

with MP3 player:

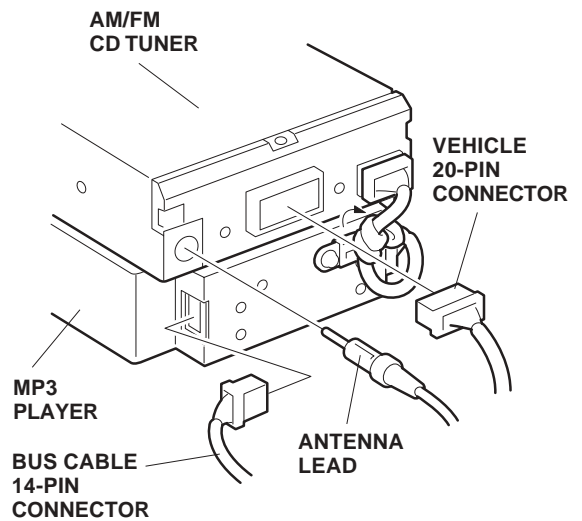

with cassette player:

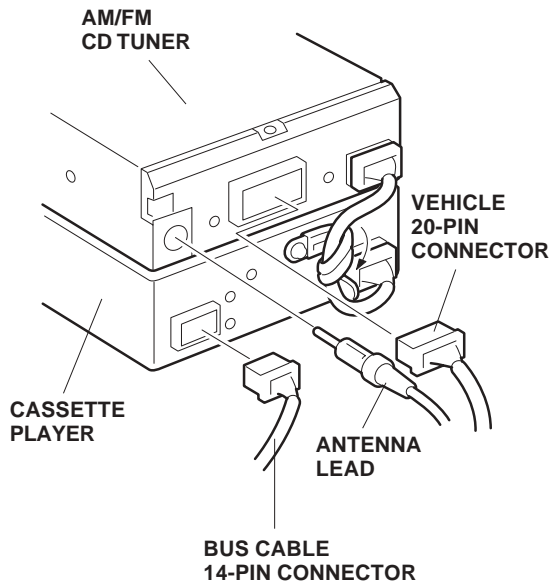

7. Plug the BUS cable 14-pin connector, the vehicle connector, and antenna lead into the back of the audio unit.

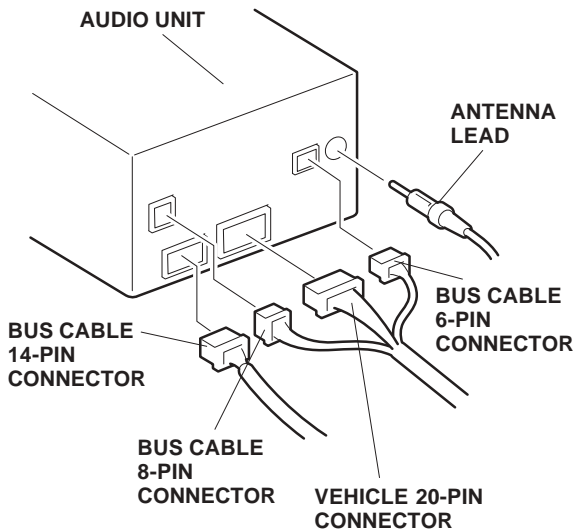

8. Slide the audio unit into the radio opening, and reinstall the four self-tapping screws.

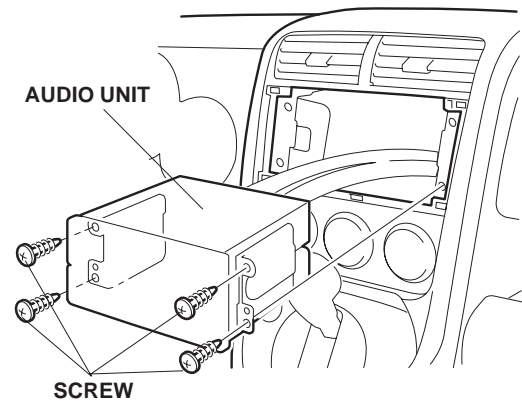

9. Check that all wire harnesses are routed properly and all connectors are plugged in.
10. Reconnect the negative cable to the battery.
11. Check the operation of the iPod Interface as described in the Owner's Manual supplied.
12. Reinstall all removed parts.
13. Put the Owner's Manual in the glove box.
14. Enter the customer's radio anti-theft code, and reset the radio station presets.

NOTE: Whenever the battery is disconnected, the driver's window AUTO function is disabled.

15. Start the engine. Push down on the driver's window switch until the window is fully open.
16. Pull up on the driver's window switch to close the window completely, then hold the switch for two seconds.
17. Test the AUTO function.
18. Do the PCM idle learn procedure.
  - Mark sure all electrical items are turned off.
  - Start the engine . Hold the engine speed at 3,000 rpm with no load (in Park or Neutral) until the radiator fan comes on.
  - Let the engine idle for about 5 minutes with the throttle fully closed and with all electrical items off.

NOTE: If the radiator fan comes on during this step, the time it is operating must not be included the 5 minutes.