



INSTALLATION INSTRUCTIONS

Accessory	Application	Publications No.
SECURITY SYSTEM	ELEMENT	All 33016
		Issue Date AUG 2006

PARTS LIST

Security System (sold separately)
P/N 08E51-EP4-101

Security unit

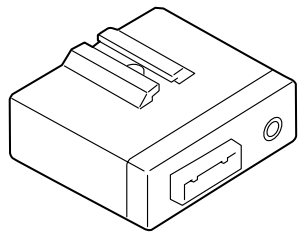

LED

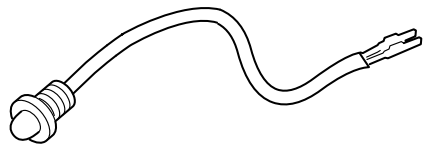

Push nut



2-pin connector (for LED)

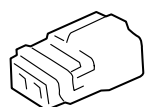

Microphone

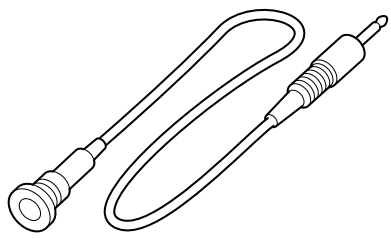

Window decal

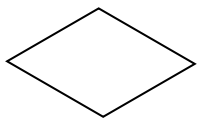

Accessory User's Information manual

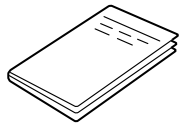

Security System Attachment (sold separately) P/N 08E55-SCV-102

Security system harness

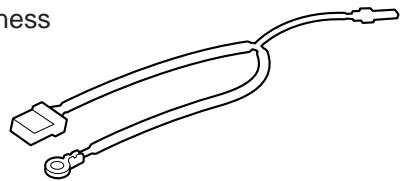

8 Wire ties

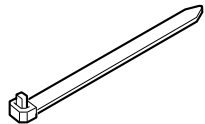

2 Cushion tapes

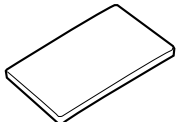

Wire tie with connector holder

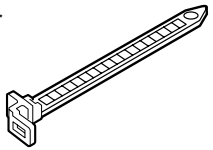

Holder bracket

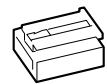

Unit bracket

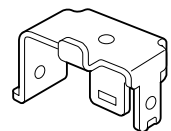

TOOLS AND SUPPLIES REQUIRED

- Phillips screwdriver
- Felt-tip pen
- Tape measure
- Eye protection (safety goggles, face shield, etc.)
- Drill
- 3 mm, 5.5 mm and 8 mm Bits
- Isopropyl alcohol
- Shop towel
- Center punch
- File
- Ratchet
- 10 mm Socket
- Electrical tape
- Masking tape

Illustration of the Security System Installed on the Vehicle

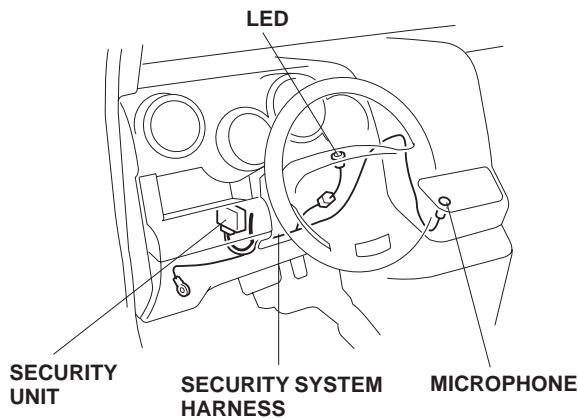

INSTALLATION

Customer Information: The information in this installation instruction is intended for use only by skilled technicians who have the proper tools, equipment, and training to correctly and safely add equipment to your vehicle. These procedures should not be attempted by "do-it-yourselfers."

1. Make sure you have the anti-theft code for the radio, then write down the frequencies for the preset buttons.
2. Disconnect the negative cable from the battery.
3. Remove the driver's dashboard lower cover, turn the knobs clockwise, then pull the lower cover out toward you to release the six retaining tabs.

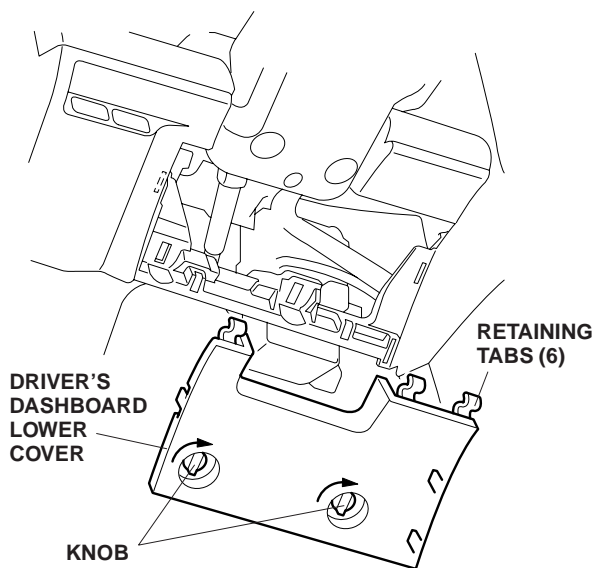

4. Lower the steering wheel using the tilt lever. Remove the two self-tapping screws and one washer-screw from the lower steering column cover.

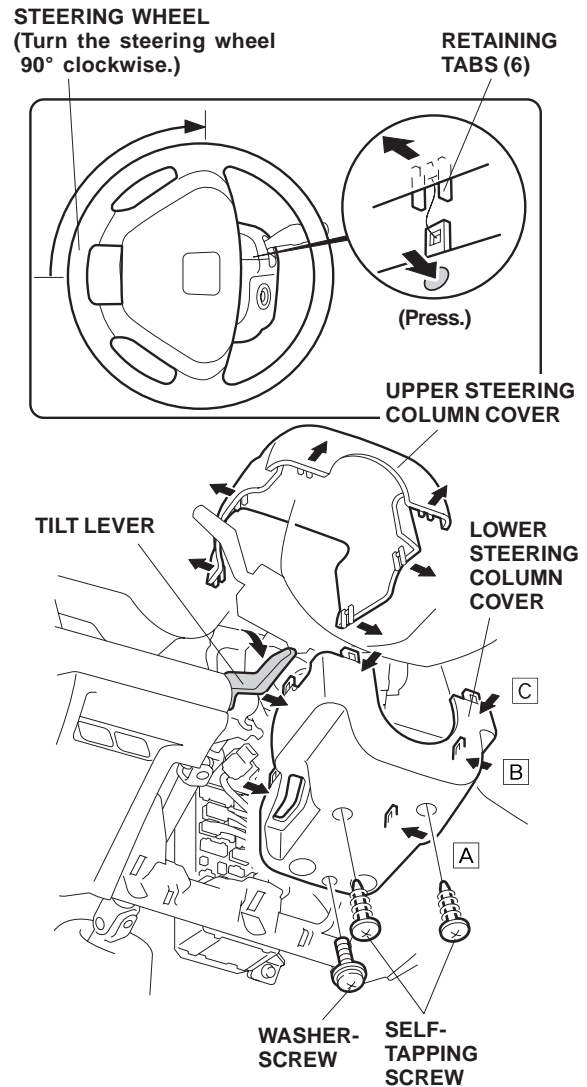

5. Separate the upper steering column cover from the lower steering column cover.
 - Turn the steering wheel 90° clockwise and, press point **A** to release the retaining tab.
 - Press point **B** and then **C** to release the retaining tabs. Once these retaining tabs are released, the retaining tabs on the opposite side will release.

- Attach pieces of masking tape to the audio panel in the areas shown. Pull the tape to release the audio panel (five clips). Take care not to damage the clips.

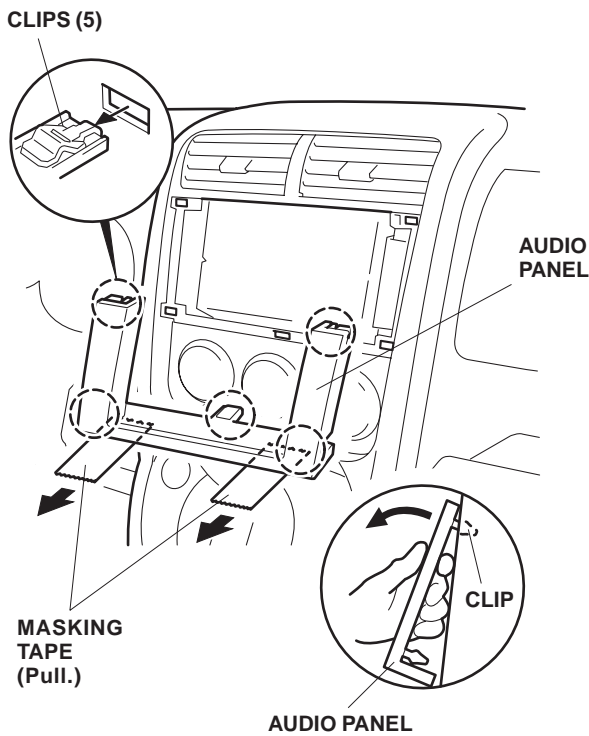

- Remove the audio unit (four washer-screws) and disconnect the vehicle connectors and the antenna connector.

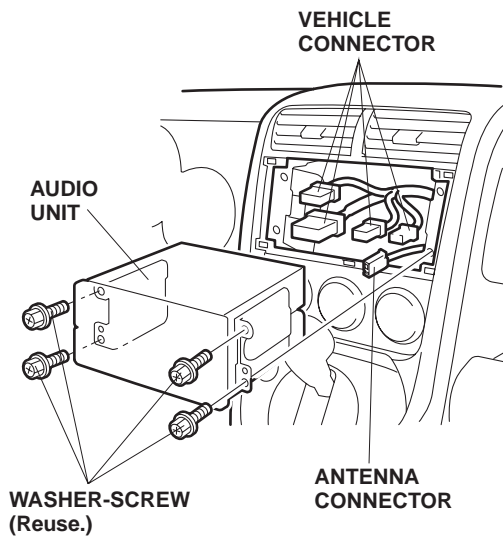

- Remove the center panel (releasing the ten clips and unplugging the vehicle connectors).

On M/T models: Slide the top of the shift boot down away from the shift knob, then remove the shift knob by turning it counterclockwise.

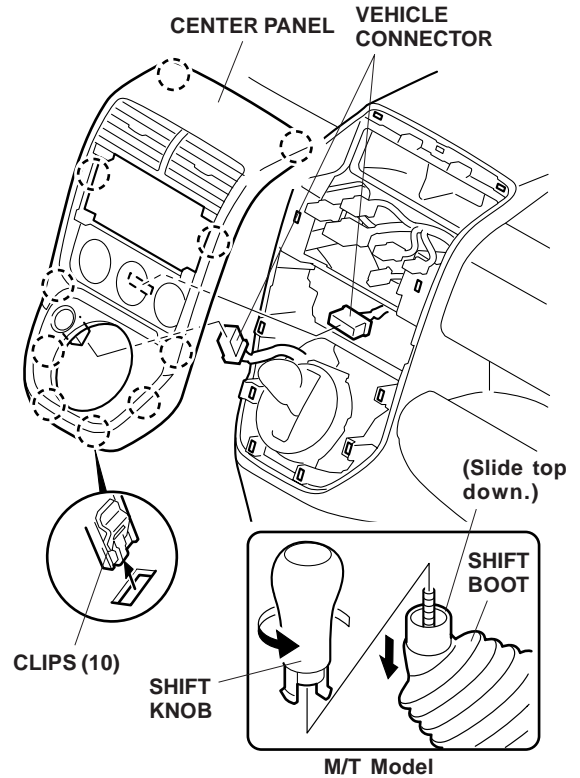

- Remove the shift lever cover from the center panel (four retaining tabs and four clips).

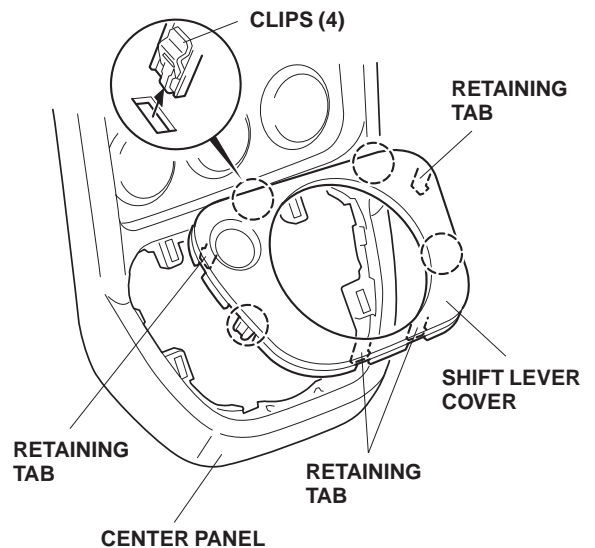

10. Measure and mark the shift lever cover at the measurement shown.

A/T Model:

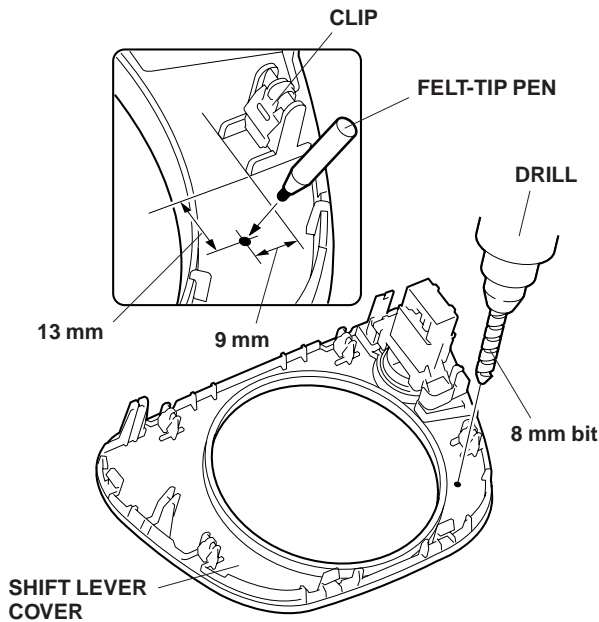

M/T Model:

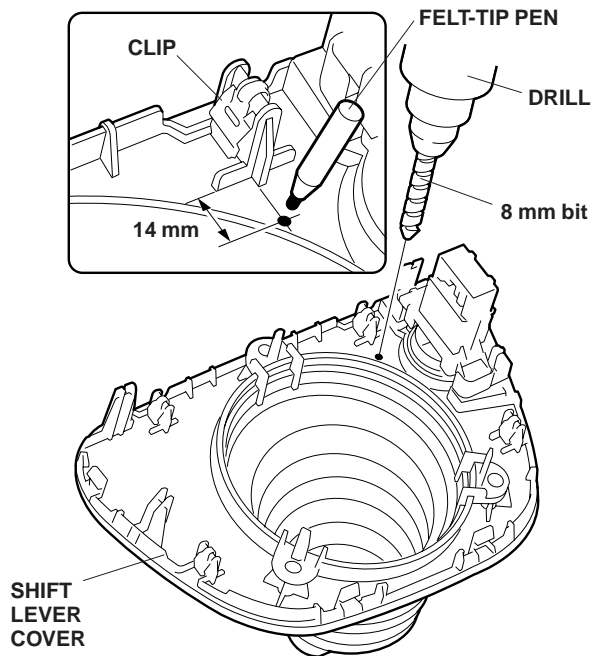

11. While wearing eye protection, lightly center-punch the mark, and drill an 8 mm hole through the center-punched mark.

- First drill a pilot hole with a 3 mm drill bit, then finish with an 8 mm drill bit.
- Remove all burrs.

12. Measure and mark the microphone cord in the area shown, and attach a piece of electrical tape to the microphone cord at the marked location.

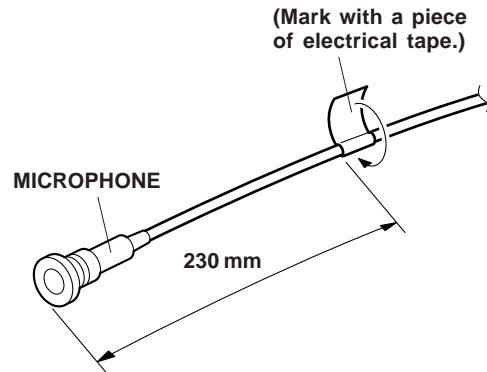

13. Reinstall the shift lever cover to the center panel. Route the microphone jack down through the hole in the shift lever cover and seat the microphone.

- If the microphone is hard to install, you may need to make the hole larger with a file.

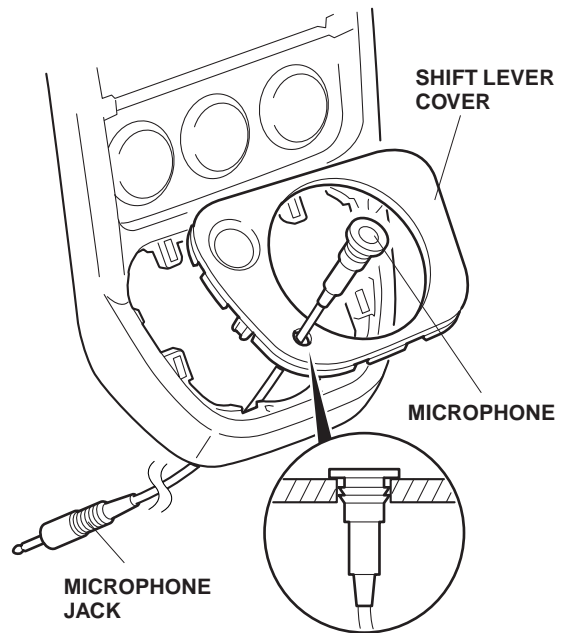

14. Measure and mark the upper steering column cover in the area shown.

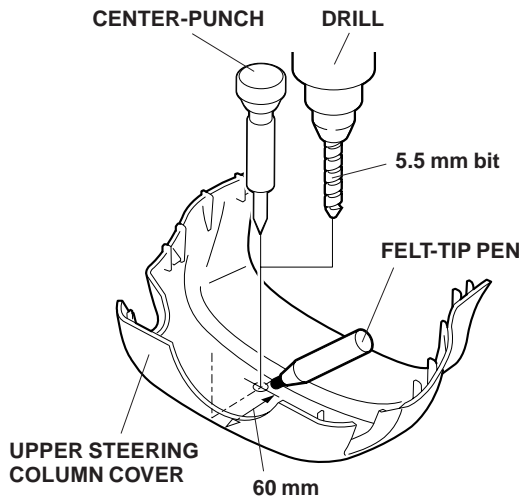

15. While wearing eye protection, lightly center-punch the mark, and drill a 5.5 mm hole through the upper steering column cover.
- First drill a pilot hole with a 3 mm drill bit, then finish with 5.5 mm drill bit.
 - Remove all burrs.
16. Route the terminal ends of the LED through the hole, and secure the LED with the push nut. Using isopropyl alcohol, clean the area where the cushion tape will attach. Secure the LED harness to the back of the upper column cover with one cushion tape.

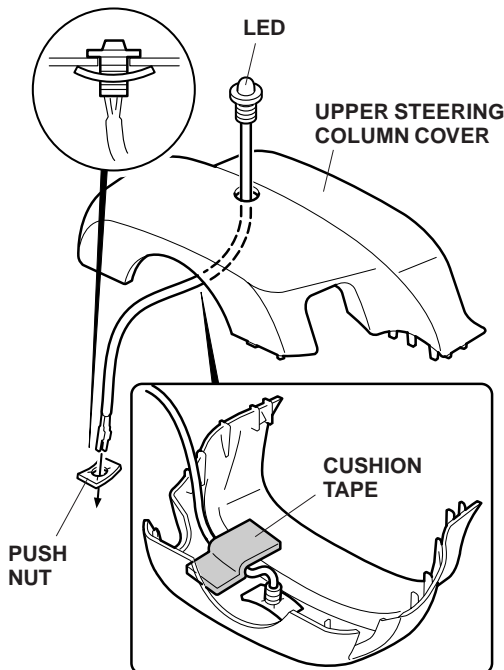

17. Locate the 2-pin connector from the kit. Firmly push the LED terminals into the 2-pin connector, and lower the lock as shown.

NOTE: If the wires are not correctly installed in the connector, the LED will not work.

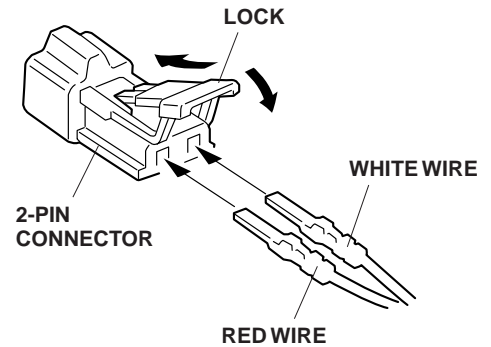

18. Under the dash, locate the 22-pin connector blue-taped to the vehicle harness and remove the blue tape to free the 22-pin connector. Remove the retainer from the 22-pin connector.

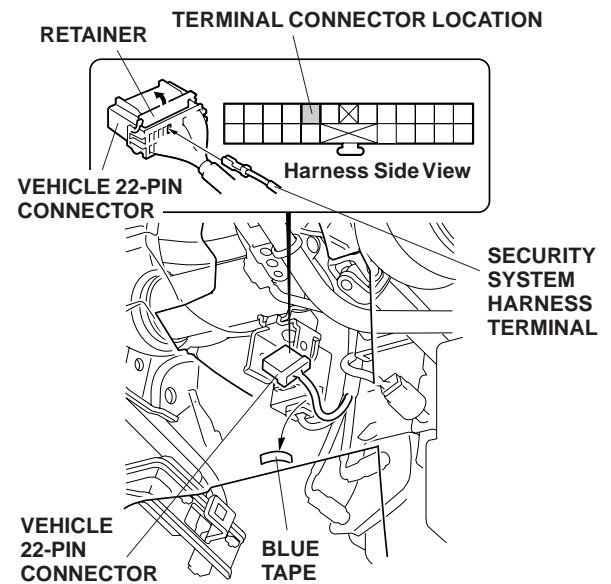

19. Push the security system harness terminal into the appropriate vehicle 22-pin connector terminal, then reinstall the retainer.

- Unplug the vehicle 5-pin connector from the receiver unit. Then, remove the vehicle bracket (one bolt).

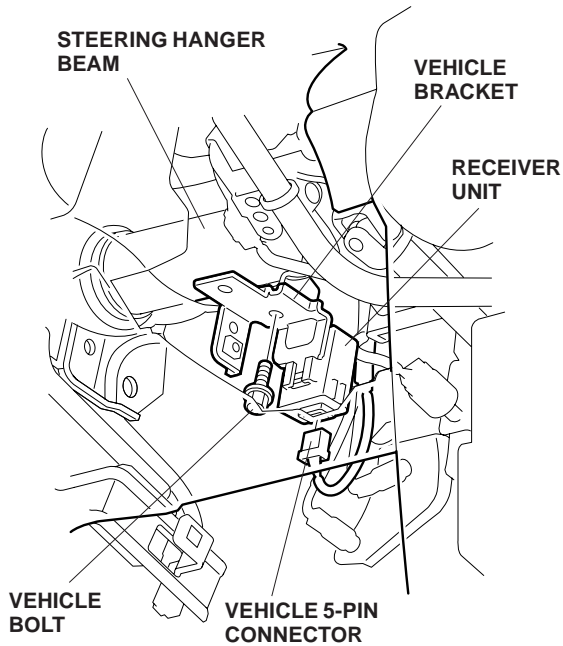

- Remove the receiver unit from the vehicle bracket.

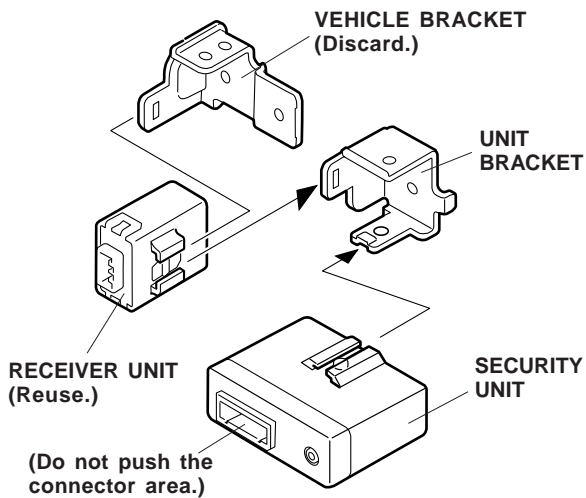

- Slide the receiver unit and the security unit onto the unit bracket.

- Plug the vehicle 22-pin connector into the security unit. Reinstall the unit bracket.

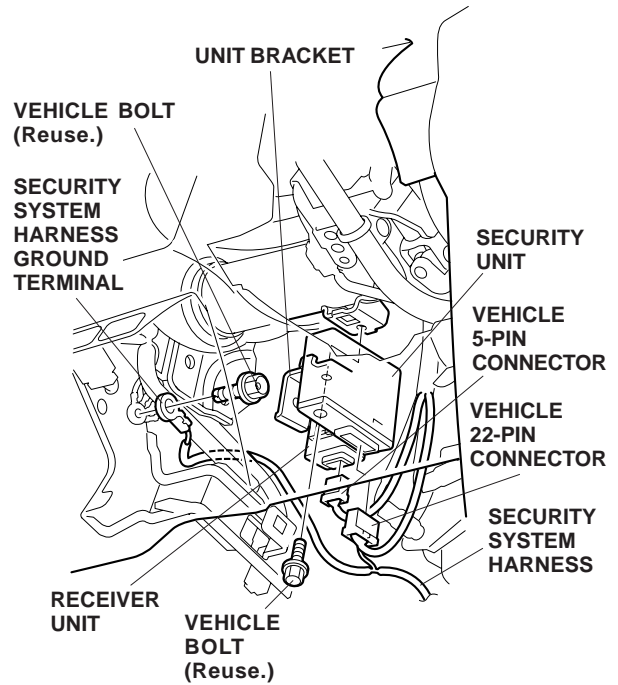

- Reconnect the vehicle 5-pin connector to the receiver unit.
- Remove the bolt that secures the vehicle ground terminal and attach the security system harness ground terminal with this bolt.

26. Reinstall the upper steering column cover, then route the LED harness along the vehicle harness.

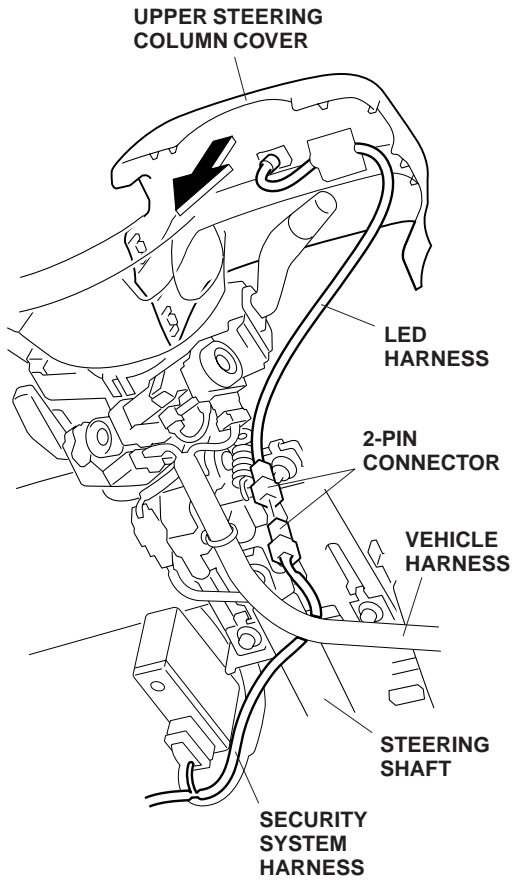

27. Route the security system harness 2-pin connector under the steering shaft, and plug it into the LED harness 2-pin connector.

28. Slide the holder bracket onto the LED harness 2-pin connector, then slide one wire tie with connector to the holder bracket. Secure the LED harness 2-pin connector to the vehicle harness with the wire tie with connector holder.

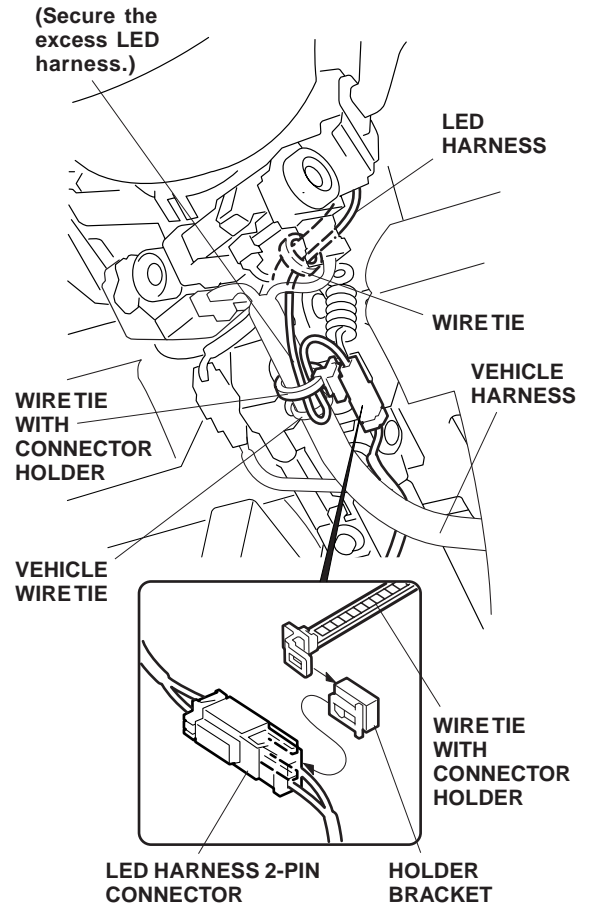

29. Secure the LED harness to the vehicle harness with one additional wire tie.
30. Reinstall the lower steering column cover to the upper steering column cover.

31. With the center panel close to the center panel opening, secure the microphone harness to the vehicle harness with one wire tie at the electrical tape you attached in step 12.

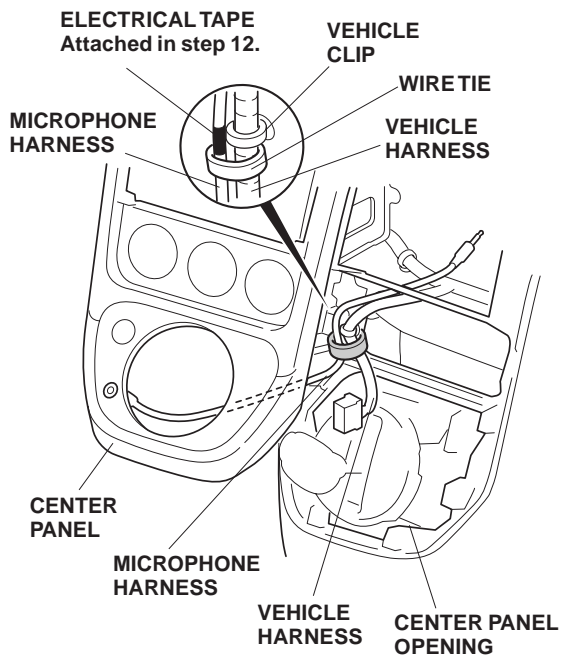

32. Route the microphone jack along the vehicle harness, and secure the microphone harness to the vehicle harness with one wire tie in the area shown.

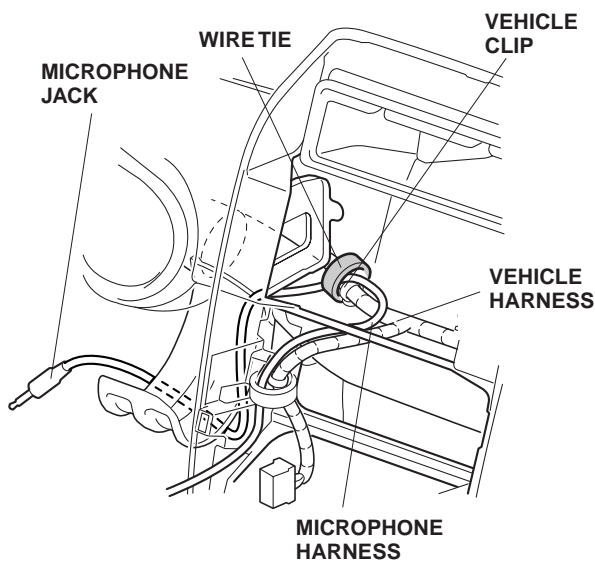

33. Secure the microphone harness to the vehicle harness with one wire tie in the area shown.

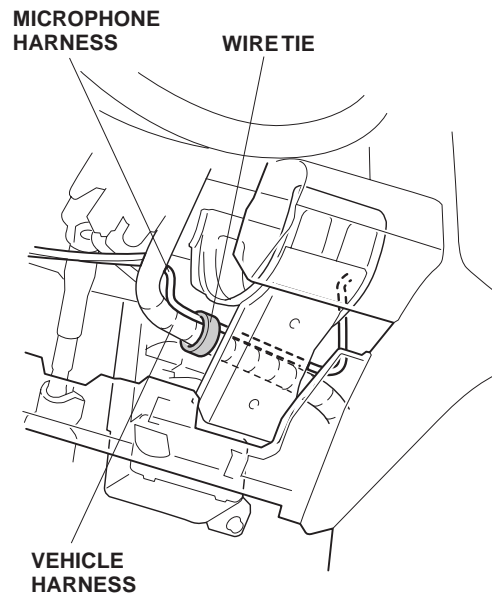

34. Route the microphone jack along the vehicle harness and security system harness, and plug the microphone jack into the security unit.

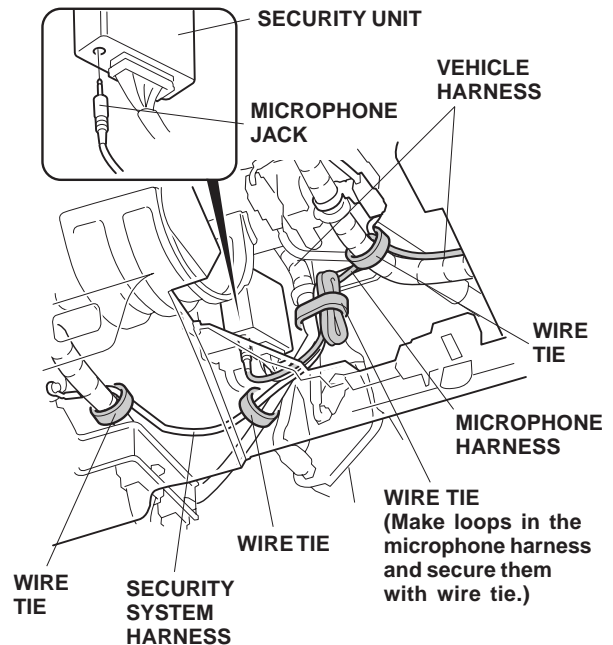

35. Secure the microphone harness and the security system harness to the vehicle harnesses with four wire ties in the areas shown.
36. Bundle up the excess microphone harness and secure the harness with one wire tie as shown.

37. Secure the microphone harness to the vehicle harness with electrical tape.

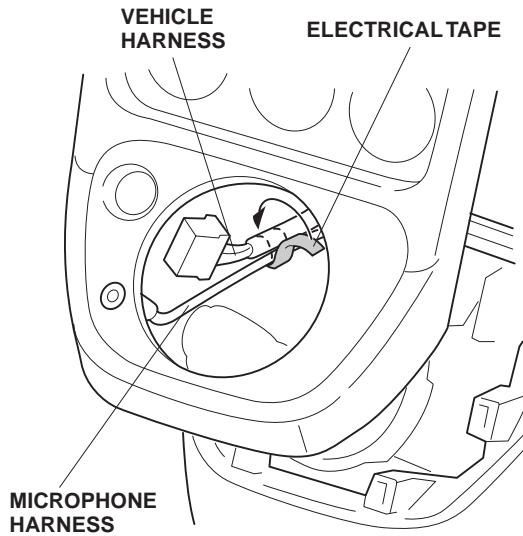

38. Check that all wire harnesses and cables are routed properly and that all connectors are plugged in.
39. Reinstall all removed parts.
40. Reconnect the negative cable to the battery.
41. Enter the customer's radio anti-theft code, and reset the radio station presets.
42. Reset the clock.
43. Check operation of the security system according to the Security System owner's manual.

NOTE: When the battery is disconnected, the driver's window AUTO function is disabled.

44. Start the engine. Push down on the driver's window switch until the window is fully open.
45. Pull up on the driver's window switch fully to close the window completely, then hold the switch for 2 seconds or more.
46. Test the window AUTO function.