

PARTS LIST

Trunk spoiler

Right trunk spring
(marked green)Left trunk spring
(marked pink)4 Washer-bolts (with thread lock),
6 mm x 12 mm

4 Butyl O-rings

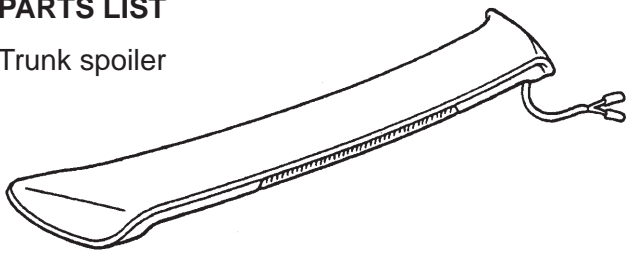
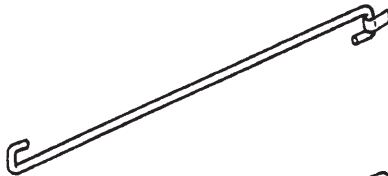
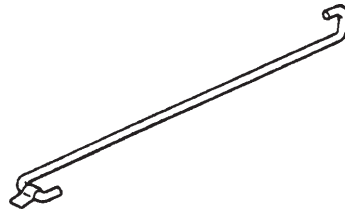

Template

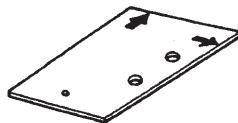

Spoiler harness

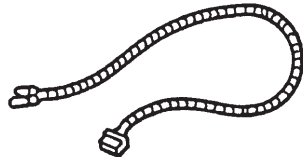
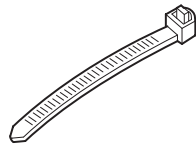
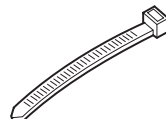
6 Long wire ties
(one not used)3 Short wire ties
(one not used)**TOOLS AND SUPPLIES REQUIRED**

Drill

3 mm, 6 mm, 8 mm, and 10 mm Drill bits

Eye protection (face shield, safety goggles, etc.)

Center punch

Felt-tip pen

Shop towel

Block of wood

#2 Phillips screwdriver

10 mm Combination wrench

10 mm Socket

Ratchet

Tape measure

Touch-up paint

Round file

Diagonal cutters

Heavy gloves

Trunk spring installer/remover
(T/N 08M10-SM4-100)**INSTALLATION**

1. Write down the customer's radio station presets; the radio memory will be erased when you disconnect the battery.

Installing the Spoiler

2. Disconnect the negative cable from the battery.
3. Open the trunk, and locate the two identification marks on each side of the trunk lid. Carefully center-punch both marks on each side.

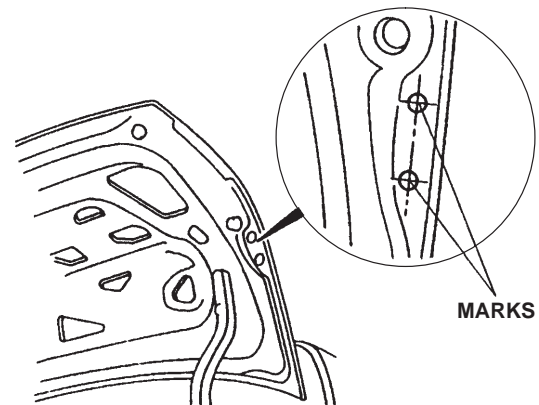

MARKS

4. While wearing eye protection, have an assistant hold the trunk lid open, and drill a 3 mm hole through each mark. Enlarge the holes with a 6 mm drill bit, then finally with an 8 mm drill bit.

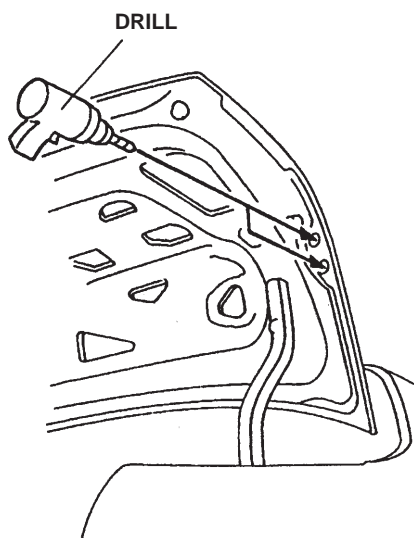

5. Remove all burrs and metal shavings, then apply touch-up paint to the edges of the holes.
6. Close the trunk lid. Position the template, printed side up, on the passenger's side of the trunk lid over the two holes you just drilled. Align the holes of the template with the holes in the trunk lid, then mark the hole in the template with a felt-tip pen.

NOTE: Mark only the passenger's side of the trunk lid. This hole is for wire harness routing.

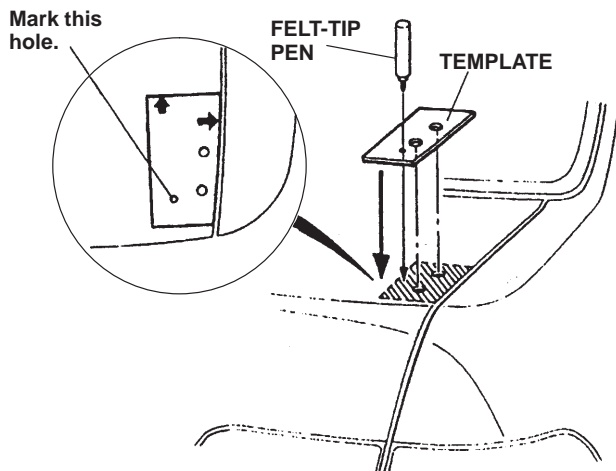

7. Place a block of wood wrapped in a shop towel between the trunk lid and the rear fender.

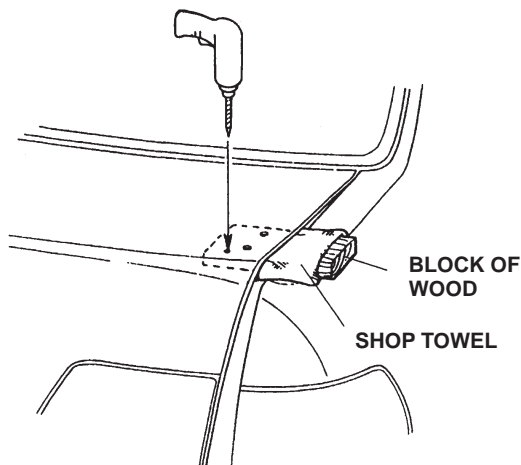

8. Center-punch the mark you made in step 6. While wearing eye protection, drill a hole only through the outer skin of the trunk lid. Start with a 3 mm drill bit, then enlarge the hole with a 6 mm drill bit, then with an 8 mm drill bit, and finally with a 10 mm drill bit.
9. Remove all burrs and metal shavings, then apply touch-up paint to the edges of the hole, and allow it to dry.
10. When the touch-up paint is dry, hold the spoiler over the trunk lid and route the wire harness from the spoiler down through the 10 mm hole in the trunk lid and out through the hole in the inner panel. Seat the grommet properly in the 10 mm hole.

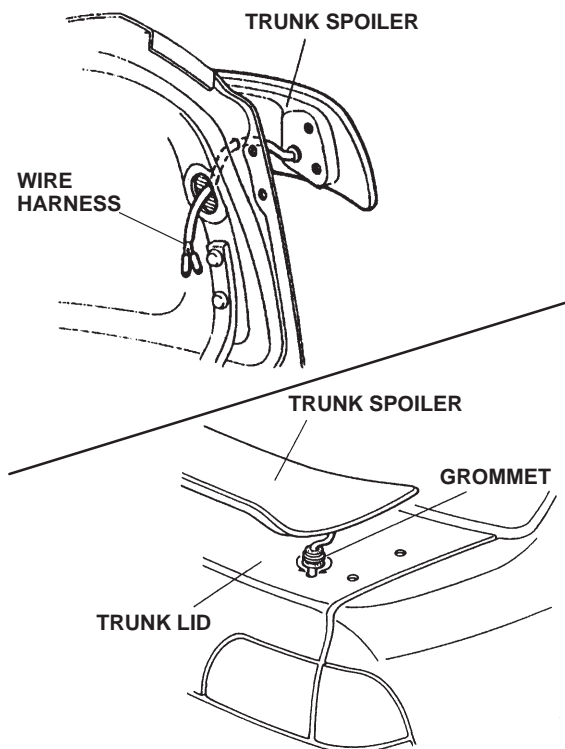

- Position the spoiler on the trunk lid, then install the four butyl O-rings and the four 6 mm x 12 mm washer-bolts. Torque the bolts to 9 N·m (6.5 lb-ft).

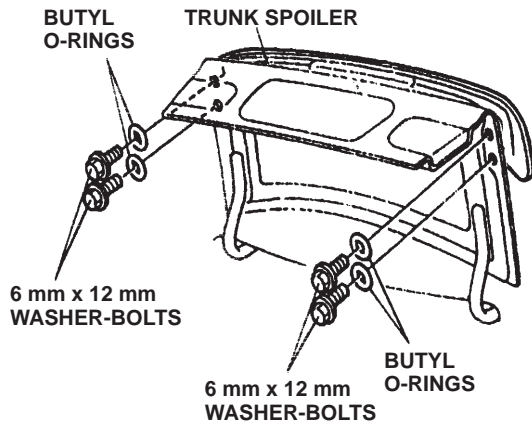

Installing the Trunk Springs

- Remove and retain the center clip from the trunk springs.
- Remove the trunk springs from the trunk hinge arms using the special tool. Wear heavy gloves to protect your hands, and pull the special tool slowly and carefully toward you.

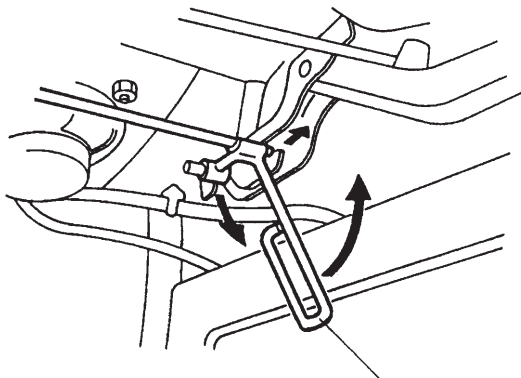

TRUNK SPRING
INSTALLER/REMOVER
T/N 08M10-SM4-100

- Install the heavy-duty springs in the reverse order of removal:
 - Set the tool on the unmarked end of each trunk spring.
 - Install the green-marked spring on the right (passenger's) side of the vehicle, and install the pink-marked spring on the left (driver's) side of the vehicle.

- While wearing heavy gloves, rotate the tool as you pull it toward you.
- Set the springs in the first notch (original position) on the hinge arm.
- Reinstall the center clip on the trunk springs.

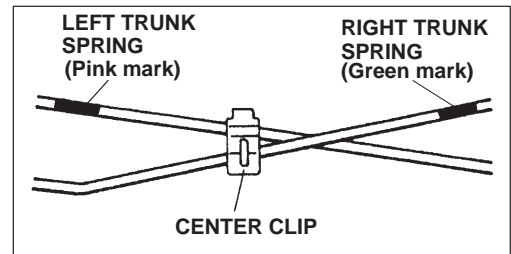
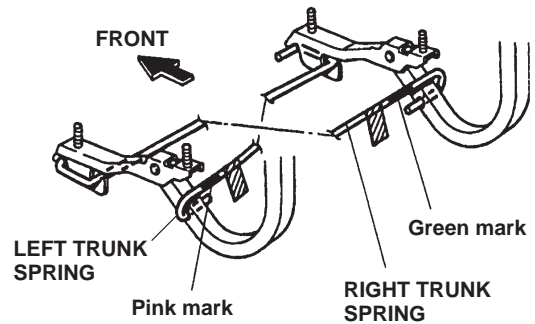

Routing the Spoiler Wire Harness

- Inside the trunk, remove the high-mount brake light bulb and socket by twisting it, then unplug the high-mount brake light 2-pin connector.

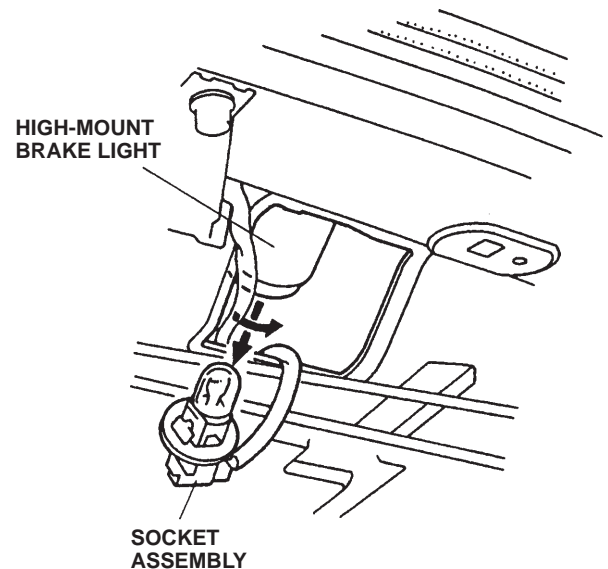

16. Connect the spoiler wire harness 2-pin connector to the high-mount brake light connector. Secure the spoiler harness 2-pin connector to the vehicle harness with one short wire tie.

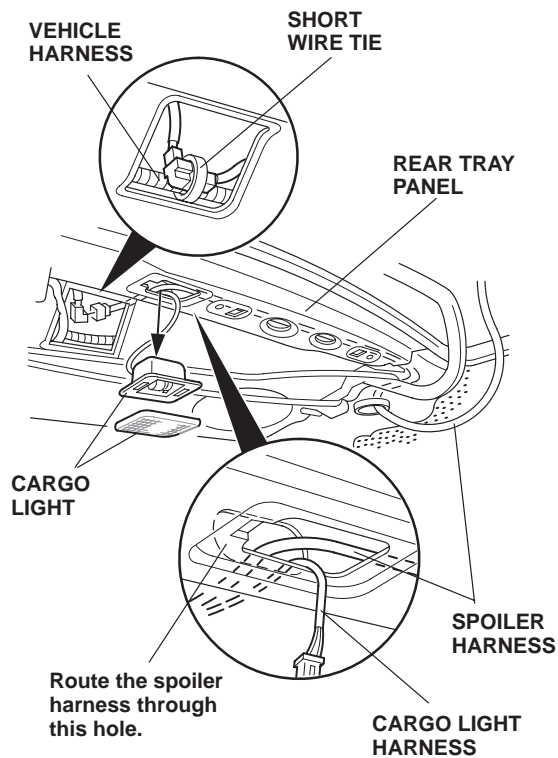

17. Remove the cargo light, then route the spoiler harness through the hole and down the rear tray panel.
18. Connect the spoiler harness to the wires from the spoiler.

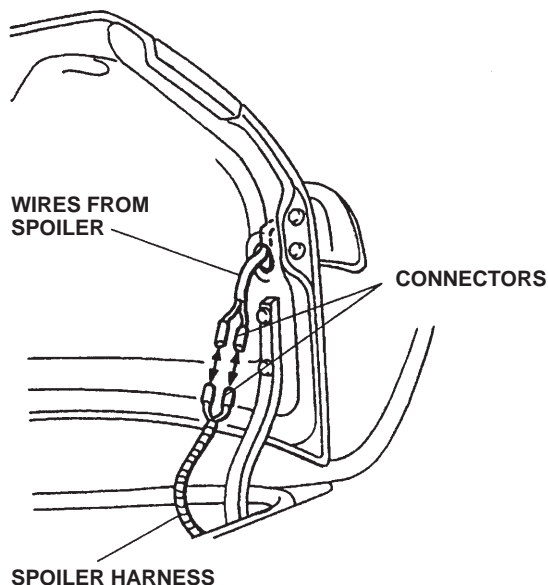

19. Secure the spoiler harness to the trunk arm hinge with five long wire ties and one short wire tie in the areas shown.

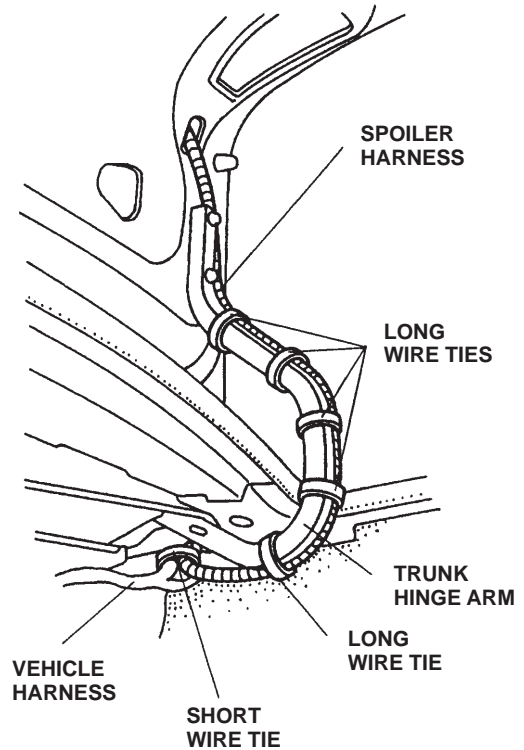

20. Reinstall the cargo light.
21. Check that all wire harnesses are routed properly and that all connectors are plugged in.
22. Cut off the excess length from the wire ties.
23. Reconnect the negative cable to the battery.
24. Reset the clock and the radio station presets.
25. Check that the spoiler brake light comes on when the brake pedal is pressed.

USE AND CARE

- Handle the spoiler with care. It is not designed to absorb impact.
- Check the spoiler mounting bolts periodically, and retighten them if necessary.