

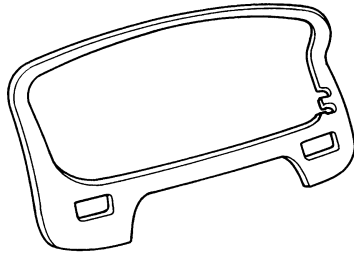

<h1>INSTALLATION INSTRUCTIONS</h1>	Accessory <b>WOOD TRIM PANEL</b> P/N 08Z03-S3V-200 08Z03-S3V-200a	Application <b>2002-2003 MDX</b>	Publications No. <b>BII 23301</b>
			Issue Date <b>NOV 2001</b>

**PARTS LIST**

Wood trim panel



**SUPPLIES REQUIRED**

- Isopropyl alcohol
- Shop towel
- Masking tape

**INSTALLATION**

**NOTE:** The wood trim panel should be installed only when the ambient air temperature is 60°F (15°C) or above.

1. Using isopropyl alcohol on a shop towel, thoroughly clean the area where the wood trim panel will be attached. Allow the isopropyl alcohol to dry completely before attaching the wood trim panel.
2. Along the top and bottom of the opening in the wood trim panel, peel back 40 to 50 mm of the four adhesive backings, and tape each one to the front of the wood trim panel with a piece of masking tape.

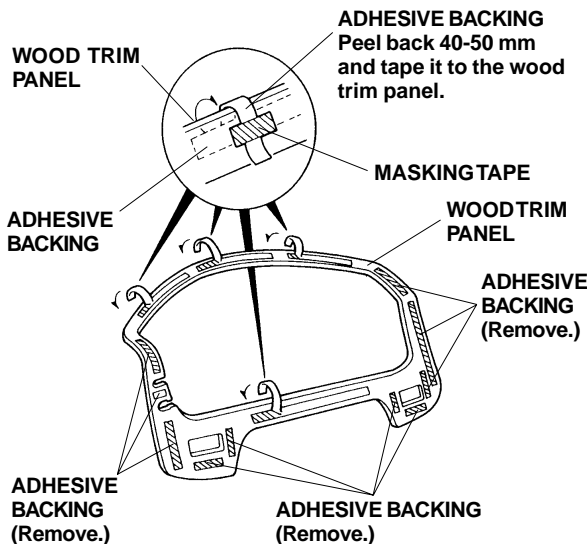

3. Remove the adhesive backing from all of the other locations.
4. Align the switch holes of the wood trim panel with the switches of the instrument panel, and attach the wood trim panel to the instrument panel.

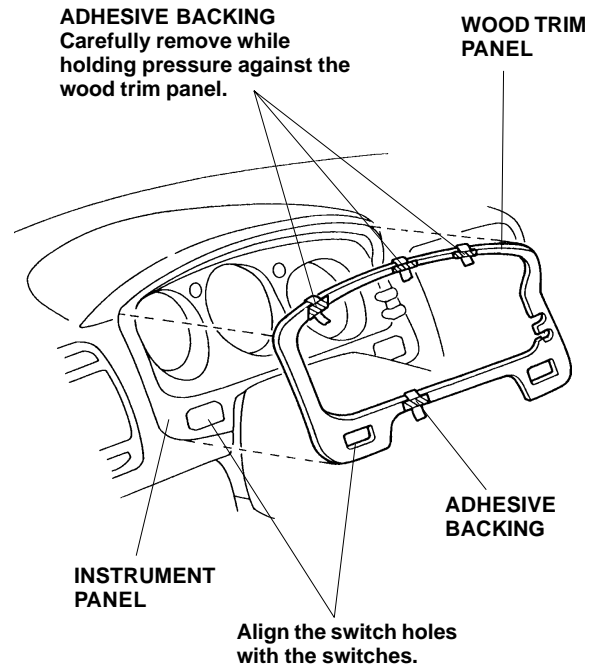

5. While applying pressure against the wood trim panel, carefully remove the four adhesive backings you taped to the wood trim panel.
6. Continue to apply pressure for at least 30 seconds after removing adhesive backings
7. Remove the masking tape.