

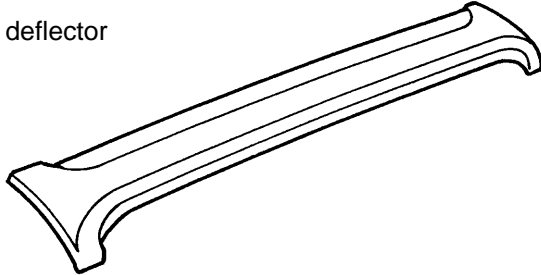

<b>INSTALLATION INSTRUCTIONS</b>	Accessory	Application	Publications No.
	<b>TAILGATE DEFLECTOR P/N 08F40-S3V-200</b>	<b>MDX</b>	<b>BII 23299</b>
			Issue Date
			<b>NOV 2001</b>

**PARTS LIST**

Tailgate deflector



4 Square-head bolts

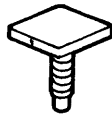

4 Cap nuts



6 Foam adhesive washers  
(2 Not used)



**TOOLS AND SUPPLIES REQUIRED**

- Ratchet
- 10 mm Socket
- Eye protection (face shield, safety goggles, etc.)
- Drill
- 3 mm and 8 mm Drill bits
- File
- Touch-up paint
- Center punch
- Torque wrench

**INSTALLATION**

**NOTE:** Be careful not to damage the tailgate and other finished surfaces of the body when installing the tailgate deflector.

1. Open the tailgate.
2. Locate the two identification marks on the tailgate. Mark and lightly center-punch the center of each mark. Repeat on the other side.

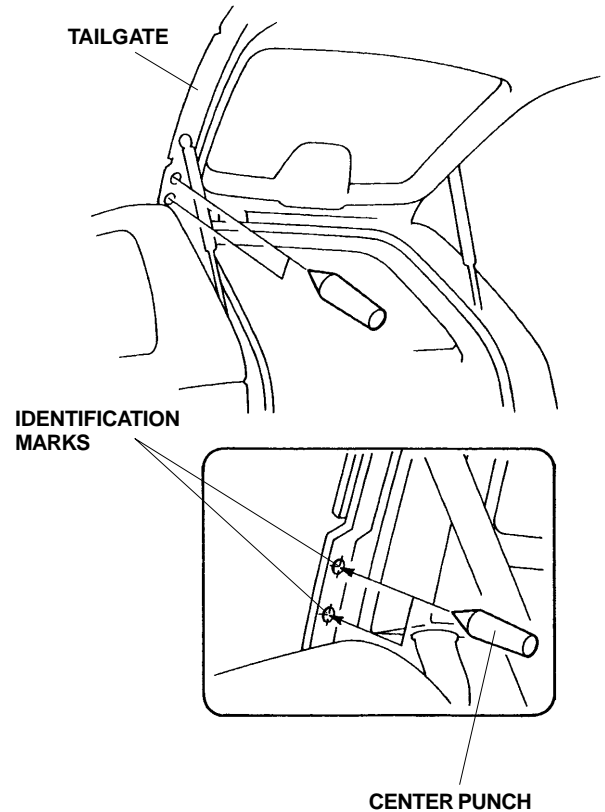

3. While wearing eye protection, drill an 8 mm hole through each mark.
  - First drill with a 3 mm bit, and finish with an 8 mm bit.
  - Remove all burrs and metal shavings, and apply touch-up paint to the edges of the holes.
  - Repeat on the other side.
  - When the touch-up paint is dry, clean the area to be covered, and wax it with a high-quality paste wax.

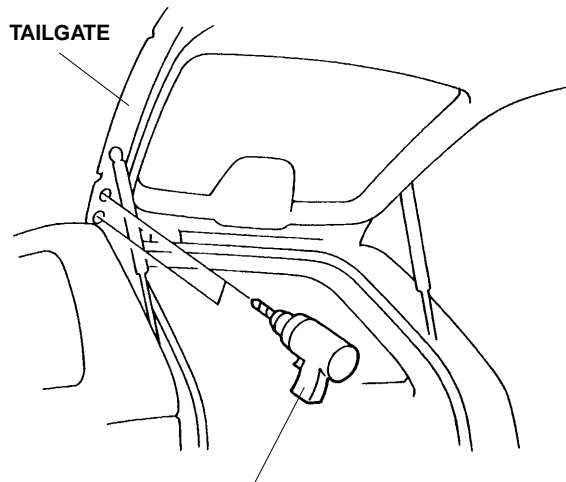

First drill pilot holes with a 3 mm bit, and finish with an 8 mm bit.

4. Remove the adhesive backing from four foam adhesive washers, and attach them to the tailgate over the holes you just drilled.

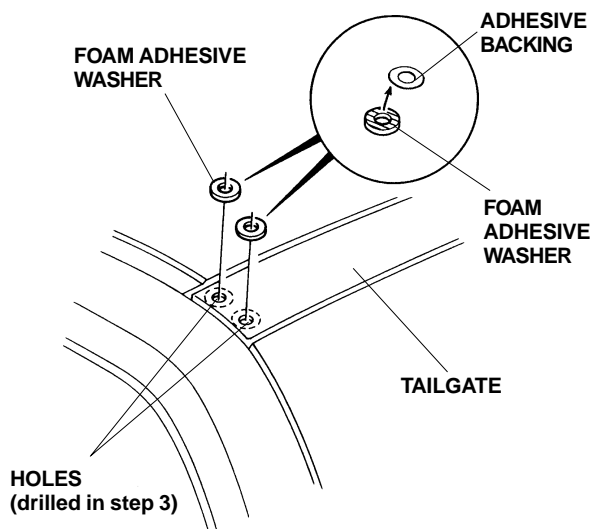

5. Install the four square-head bolts on the back of the tailgate deflector.

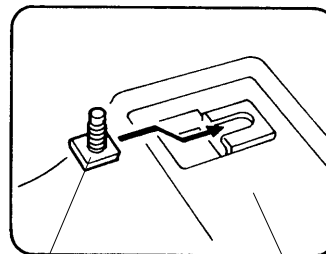
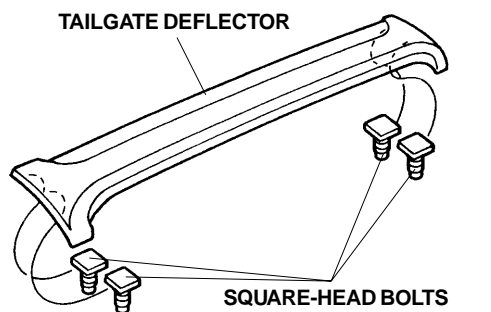

SQUARE-HEAD BOLT TAILGATE DEFLECTOR

6. Insert the bolts through the four holes you made in step 3. Adjust the deflector so that it is positioned evenly on both sides of the tailgate.

Position the deflector evenly on both sides.

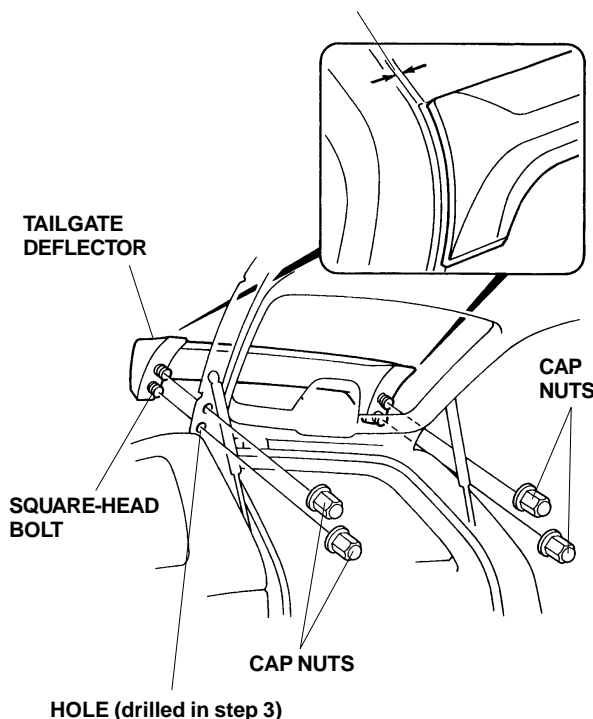

7. Install a cap nut on the end of each bolt, and torque the cap nuts to 7 to 10 N•m (5 to 7 lb-ft).